

MODEL No.:

19370-01G

NOTE: Information herein is believed by Southwest Microwave, Inc. to be accurate. However, Southwest Microwave assumes no responsibility for any omissions or errors or inaccuracies for its use or for any infringements of patents or other rights of third parties that may result from its use. Data is intended for informational purpose only and does not constitute a contract of sale or any express or implied warranty, including any warranty of merchant ability or fitness for a particular purpose.

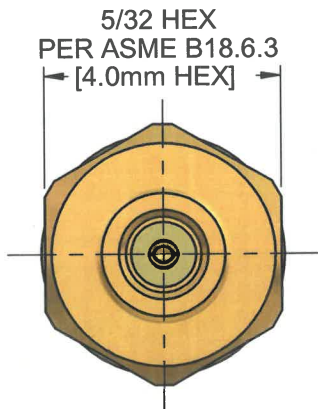

DOCUMENT CONTROL  
AUG 02 2022

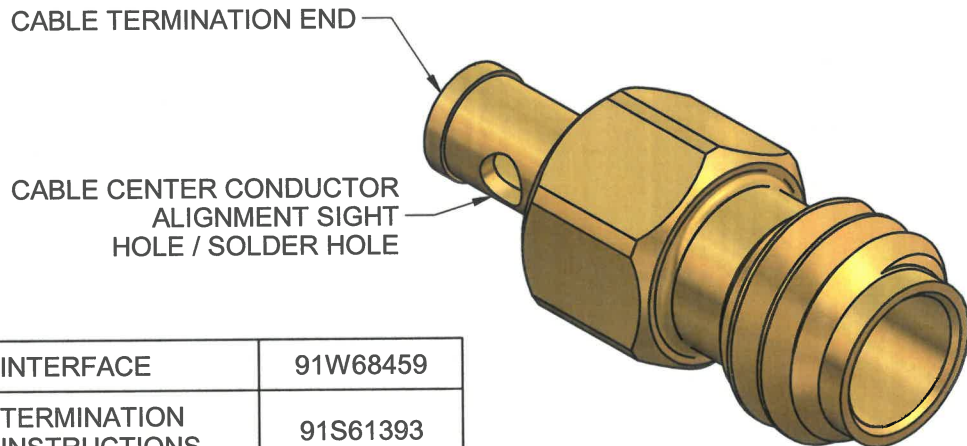
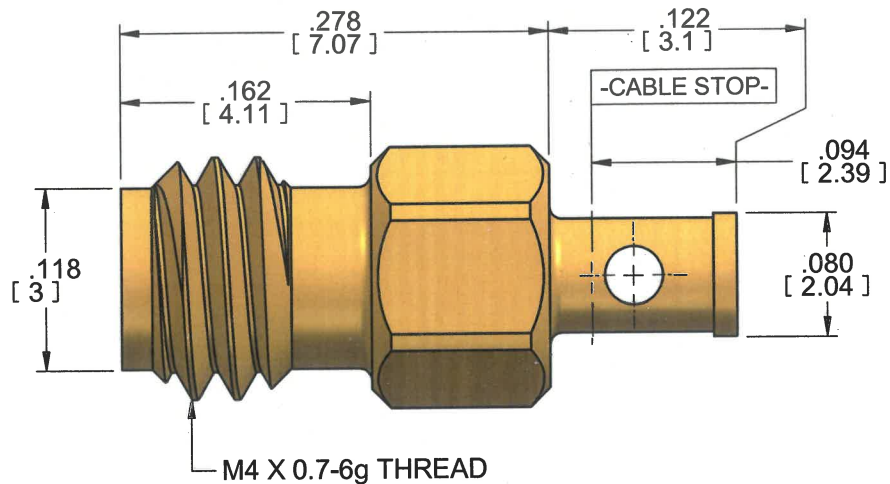

HOUSING: BUSHING:	BeCu ALLOY UNS-C17300, TEMPER TD04 PER ASTM B196/197 GOLD PLATE PER MIL-DTL-45204, TYPE II, GRADE C, NICKEL HARDENED OVER ELECTROLESS NICKEL PER MIL-C-26074.
CONTACT:	BeCu ALLOY UNS-C17300, TEMPER TD04 PER ASTM B196/197 GOLD PLATE PER ASTM B488, TYPE II, CODE C, CLASS 1.27 OVER ELECTRO-PLATED NICKEL PER SAE AMS-QQ-N-290 CLASS 1
CAPTURE BEAD:	ULTEM 1000 PER ASTM D5205
ITEM	MATERIAL & FINISH

INTERFACE	91W68459
TERMINATION INSTRUCTIONS	91S61393
SPECIFICATION GROUP	DWG NO.

2. PERFORMANCE IS DEPENDENT UPON THE SPECIFIC CABLE SELECTION AND THIRD-PARTY CABLE PREPARATION BEYOND THE CONTROL OF SOUTHWEST MICROWAVE.

1. ALL DIMENSIONS ARE IN INCHES. ALL ANGLES ARE IN DEGREES. DIMENSIONS SHOWN IN BRACKETS [XXX] ARE IN MILLIMETERS.

NOTES: UNLESS OTHERWISE SPECIFIED.

REV: A	RELEASE	APRVD. DE	DATE: 8/1/22	TITLE
 Southwest Microwave, Inc. 9055 South McKemy Street Tempe, Arizona 85284-2946 Telephone (480) 783-0201 Fax (480) 783-0360				1.0mm, J, DS, .047SC CBL
				DRN BY: T. CLARE
				SCALE 8:1
				DWG. NO. 79WV61437
				SHEET: 1 OF 1