

NOTE: Information herein is believed by Southwest Microwave, Inc. to be accurate. However, Southwest Microwave assumes no responsibility for any omissions or errors or inaccuracies for its use or for any infringements of patents or other rights of third parties that may result from its use. Data is intended for informational purpose only and does not constitute a contract of sale or any express or implied warranty, including any warranty of merchant ability or fitness for a particular purpose.

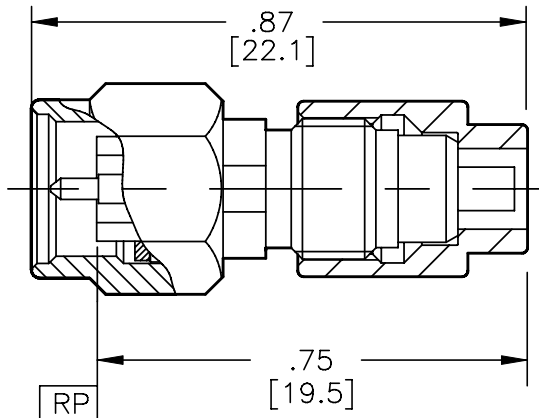
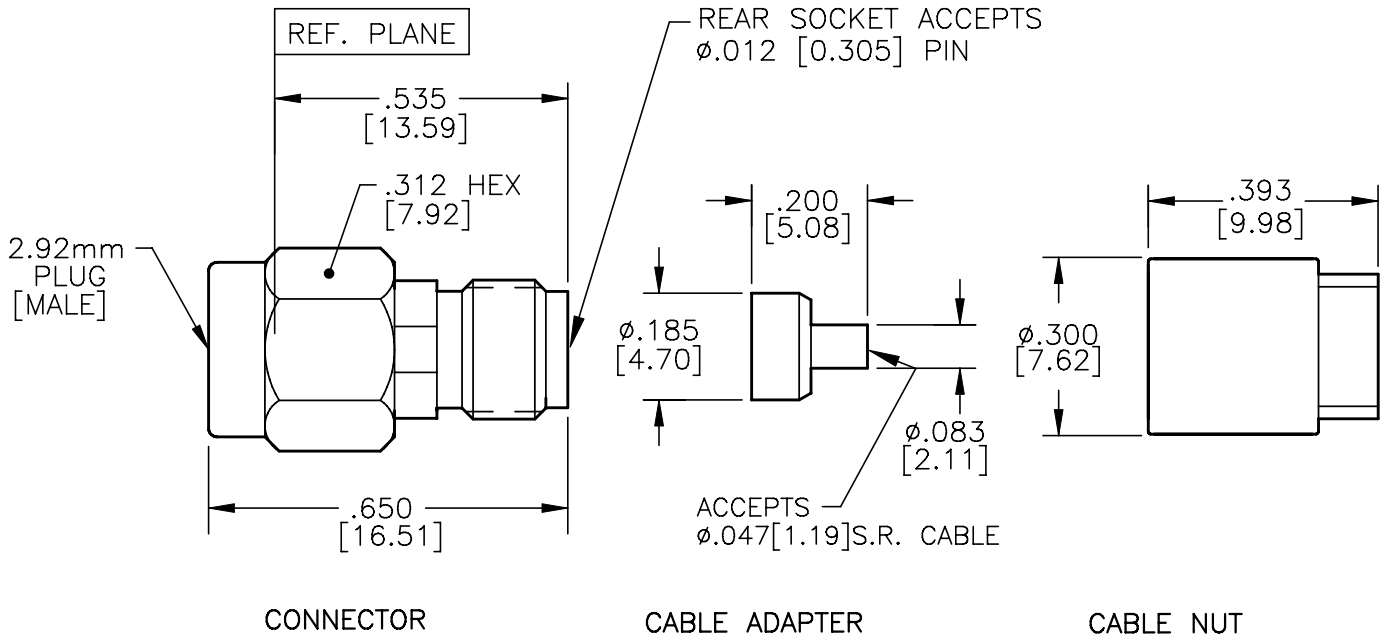

HOUSING: COUPLING NUT:	STEEL, CRES ALLOY UNS-S30300 PER ASTM-A582. PASSIVATE PER ASTM-A967-99
CONTACT:	BeCu UNS-C17300 PER ASTM-B-196/197 GOLD PLATE PER MIL-G-45204
BEAD RING:	1) ULTEM 1000 PER ASTM-D-5205 2) KEL-F PER MIL-P-46036
RETAINING RING:	BeCu UNS-C17300 PER ASTM-B-196/197
GASKET:	SILICONE RUBBER PER ZZ-R-765
CABLE ADAPTER:	BRASS, COPPER ALLOY UNS#C36000 PER ASTM-B-16/249. GOLD PLATE PER MIL-G-45204
CABLE NUT:	STEEL, CRES ALLOY UNS-S30300 PER ASTM-A582. PASSIVATE PER ASTM-A967-99
ITEM	MATERIAL & FINISH

2. INTERFACE I.A.W. MIL-STD-348

1. ALL DIMENSIONS ARE IN INCHES, ALL ANGLES ARE IN DEGREES. DIMENSIONS SHOWN IN BRACKETS [XXX] ARE MILLIMETERS.

TOLERANCES ARE BASED UPON DIMENSIONS IN INCHES. METRIC DIMENSIONS ARE FOR "REFERENCE ONLY".

NOTES: UNLESS OTHERWISE SPECIFIED

CABLE ASSY. INSTR.	91S59287
CONTACT SPECIFICATIONS	91B52104
SPECIFICATIONS	91K52079
INTERFACE	91K52018
SPECIFICATION GROUP	DRAWING NO.

REV B	ECN: 8358	INIT: SS	DATE: 7/17/06	APRVD. EJO	DATE: 8/2/06
----------	--------------	-------------	------------------	---------------	-----------------



Southwest Microwave, Inc.
9055 South McKerny Street
Tempe, Arizona 85284-2946
Telephone (480) 783-0201
Fax (480) 783-0360

TITLE 2.92mm PLUG CABLE CONNECTOR TO ACCEPT .047 SEMI-RIGID CABLE			
DRN BY: DK	DATE: 11/97	MODEL NO.	1001-03SF
SCALE: 3:1		DWG. NO.	79K55175
SHEET: 1 OF 1			REV. B