

NOTE: Information herein is believed by Southwest Microwave, Inc. to be accurate. However, Southwest Microwave assumes no responsibility for any omissions or errors or inaccuracies for its use or for any infringements of patents or other rights of third parties that may result from its use. Data is intended for informational purpose only and does not constitute a contract of sale or any express or implied warranty, including any warranty of merchant ability or fitness for a particular purpose.

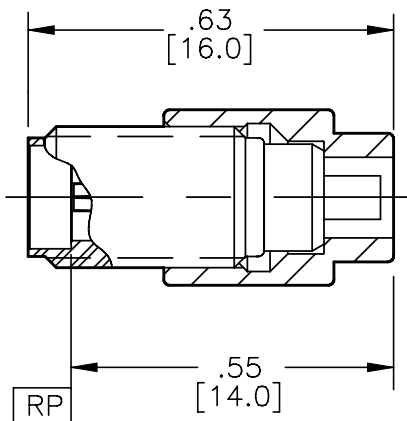
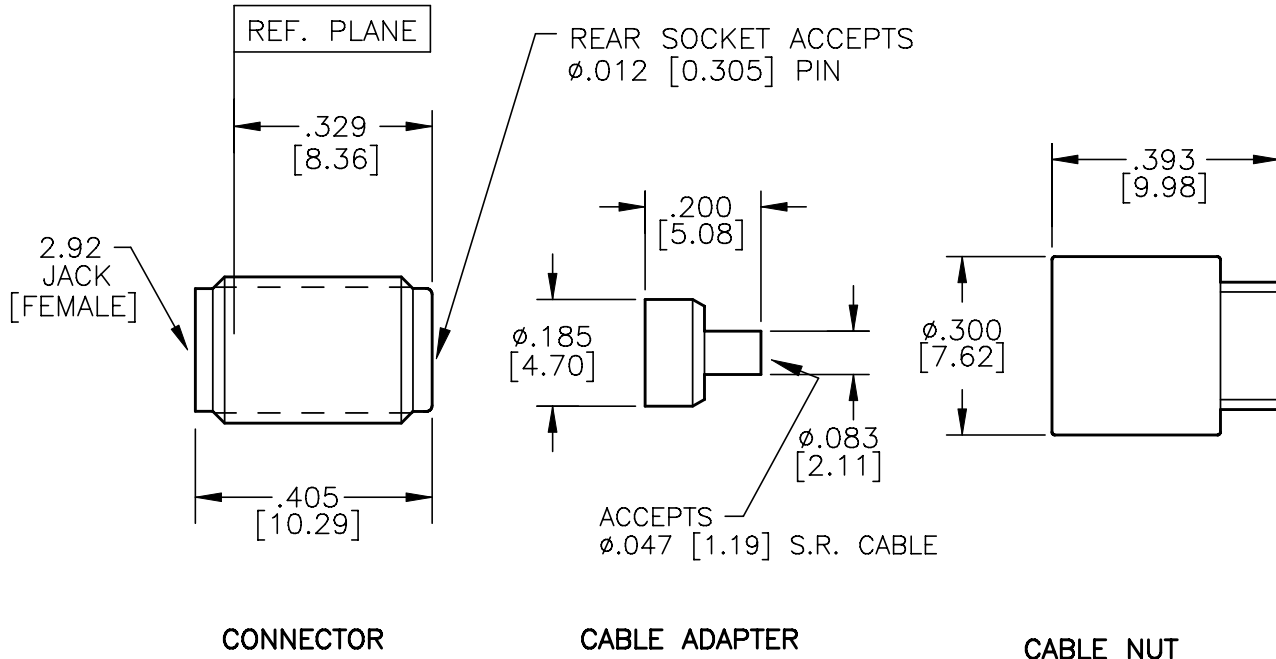

| | |
|----------------|--|
| HOUSING: | STEEL, CRES ALLOY UNS-S30300 PER ASTM-A582. PASSIVATE PER ASTM-A967-99 |
| CONTACT: | BeCu UNS-C17300 PER ASTM-B-196/197 GOLD PLATE PER MIL-G-45204 |
| BEAD RING: | 1) ULTEM 1000 PER ASTM-D-5205 2) KEL-F PER MIL-P-46036 |
| CABLE ADAPTER: | BRASS, COPPER ALLOY UNS#C36000 PER ASTM-B-16/249. GOLD PLATE PER MIL-G-45204 |
| CABLE NUT: | STEEL, CRES ALLOY UNS-S30300 PER ASTM-A582. PASSIVATE PER ASTM-A967-99 |
| ITEM | MATERIAL & FINISH |

2. INTERFACE I.A.W. MIL-STD-348

1. ALL DIMENSIONS ARE IN INCHES, ALL ANGLES ARE IN DEGREES. DIMENSIONS SHOWN IN BRACKETS [XXX] ARE MILLIMETERS.

TOLERANCES ARE BASED UPON DIMENSIONS IN INCHES. METRIC DIMENSIONS ARE FOR "REFERENCE ONLY".

NOTES: UNLESS OTHERWISE SPECIFIED

| | |
|------------------------|-------------|
| CABLE ASSY. INSTR. | 91S59287 |
| CONTACT SPECIFICATIONS | 91K52116 |
| SPECIFICATIONS | 91K52077 |
| INTERFACE | 91K52019 |
| SPECIFICATION GROUP | DRAWING NO. |

| | | | | | |
|----------|--------------|-------------|------------------|---------------|-----------------|
| REV B | ECN: 8358 | INIT: SS | DATE: 7/18/06 | APRVD. EJO | DATE: 8/2/06 |
|----------|--------------|-------------|------------------|---------------|-----------------|



Southwest Microwave, Inc.
9055 South McKerny Street
Tempe, Arizona 85284-2946
Telephone (480) 783-0201
Fax (480) 783-0360

TITLE
2.92mm JACK CABLE CONNECTOR
TO ACCEPT .047 SEMI-RIDID CABLE

| | | | | |
|---------------|----------------|-----------|-----------|-----------|
| DRN BY: DK | DATE: 11/97 | MODEL NO. | 1002-03SF | REV. B |
| SCALE: 3:1 | SHEET: 1 OF 1 | DWG. NO. | | |