

CONFIDENTIAL
 PROPRIETARY INFORMATION OF
 SOUTHWEST MICROWAVE, INC.
 THIS DOCUMENT SHALL NOT BE
 REPRODUCED IN ANY MANNER

NOTE: Information herein is believed by Southwest Microwave, Inc. to be accurate. However, Southwest Microwave assumes no responsibility for any omissions or errors or inaccuracies for its use or for any infringements of patents or other rights of third parties that may result from its use. Data is intended for informational purpose only and does not constitute a contract of sale or any express or implied warranty, including any warranty of merchant ability or fitness for a particular purpose.

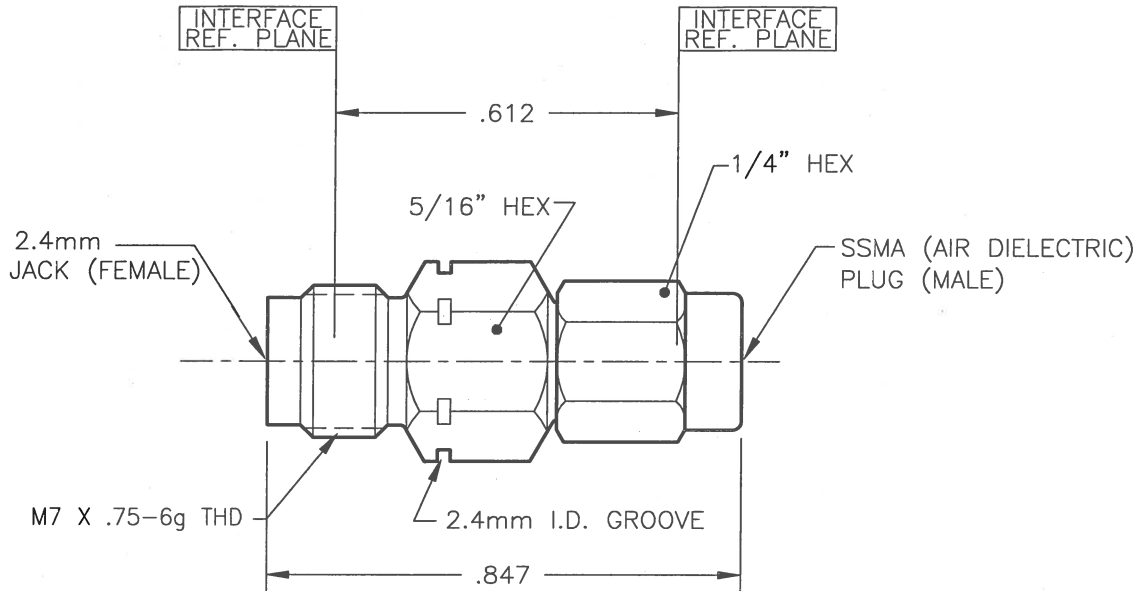

HOUSING: COUPLING NUT:	STEEL, CRES ALLOY UNS-S30300 PER ASTM-A582. PASSIVATE PER QQ-P-35.
CONTACT:	BeCu UNS-C17300 PER ASTM-B-196/197 GOLD PLATE PER MIL-G-45204
BEAD RING:	1) KEL-F PER MIL-P-46036 2) ULTEM 1000 PER ASTM-D-5205
RETAINING RING:	BeCu UNS-C17300 PER ASTM-B-196/197
GASKET:	SILICONE RUBBER PER ZZ-R-765
MATERIAL & FINISH	

PRODUCT DESIGN SPECS.	91Y58295
SPECIFICATION GROUP	DOC. No.

3. SSMA AIR DIELECTRIC PLUG INTERFACE.
2. 2.4mm INTERFACE IAW MIL-STD-348.
1. ALL DIMENSIONS ARE IN INCHES, ALL ANGLES ARE IN DEGREES.

NOTES: UNLESS OTHERWISE SPECIFIED

REV A	RELEASE	DATE 5/2/04	APRVD. <i>B. Olyatt</i>	DATE 5/9/04	TITLE MODEL 11430-00SF (50 ohm airline) SSMA (M) TO 2.4mm (F) ADAPTER
 Southwest Microwave, Inc. 9055 South McKemy Street Tempe, Arizona 85284-2946 Telephone (480) 783-0201 Fax (480) 783-0360					DRN BY: EJO DATE: 5/04 SCALE: 3:1 SHEET: 1 OF 1
					DWG. NO. 79Y57999 REV. A