

CONFIDENTIAL
 PROPRIETARY INFORMATION OF
 SOUTHWEST MICROWAVE, INC.
 THIS DOCUMENT SHALL NOT BE
 REPRODUCED IN ANY MANNER

NOTE: Information herein is believed by Southwest Microwave, Inc. to be accurate. However, Southwest Microwave assumes no responsibility for any omissions or errors or inaccuracies for its use or for any infringements of patents or other rights of third parties that may result from its use. Data is intended for informational purpose only and does not constitute a contract of sale or any express or implied warranty, including any warranty of merchant ability or fitness for a particular purpose.

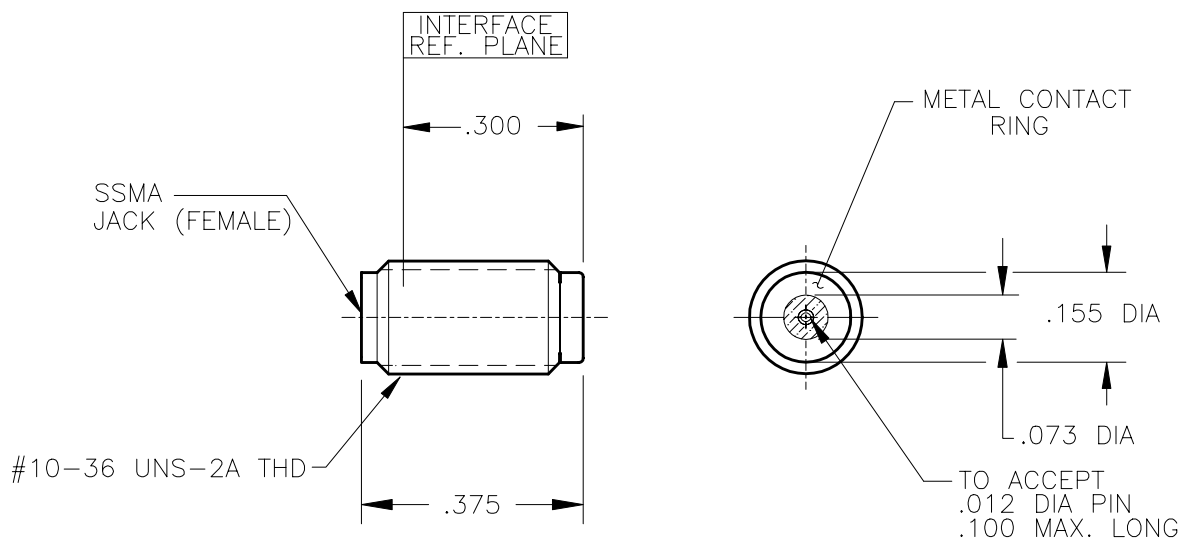

HOUSING:	STEEL, CRES ALLOY UNS-S30300 PER ASTM-A582. PASSIVATE PER QQ-P-35.
CONTACT:	BeCu UNS-C17300 PER ASTM-B-196/197 GOLD PLATE PER MIL-G-45204
DIELECTRIC INSULATOR:	VIRGIN TFE FLUOROCARBON PER ASTM-D-1710 AND ASTM-D-1457
BEAD RING:	ULTEM 1000 PER ASTM-D-5205
MATERIAL & FINISH	

PRODUCT DESIGN SPECS.	91A58055
SPECIFICATION GROUP	DOC. No.

2. INTERFACE IN ACCORDANCE TO MIL-STD-348.
 1. ALL DIMENSIONS ARE IN INCHES, ALL ANGLES ARE IN DEGREES.

NOTES: UNLESS OTHERWISE SPECIFIED

REV A1	ECN: 8076	INIT: EJO	DATE: 5/7/04	APRVD. B.CLYATT	DATE: 5/7/04
-----------	--------------	--------------	-----------------	--------------------	-----------------

TITLE
 MODEL 120-01SF
 SSMA JACK THREAD-IN .375 LONG
 TO ACCEPT .012 DIA. PIN



Southwest Microwave, Inc.
 9055 South McKerny Street
 Tempe, Arizona 85284-2946
 Telephone (480) 783-0201
 Fax (480) 783-0360

DRN BY: EJO	DATE: 12/03
SCALE: 3:1	
SHEET: 1 OF 1	

DWG. NO.
 79A58046

REV.
 A1