

NOTE: Information herein is believed by Southwest Microwave, Inc. to be accurate. However, Southwest Microwave assumes no responsibility for any omissions or errors or inaccuracies for its use or for any infringements of patents or other rights of third parties that may result from its use. Data is intended for informational purpose only and does not constitute a contract of sale or any express or implied warranty, including any warranty of merchant ability or fitness for a particular purpose.

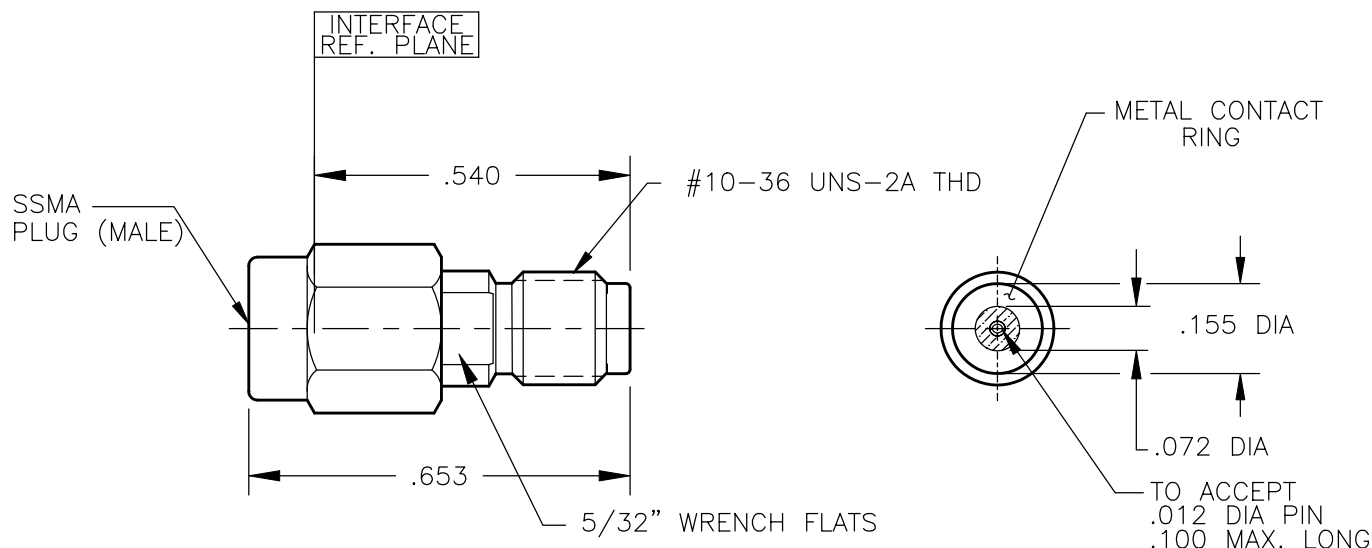

HOUSING: COUPLING NUT:	STEEL, CRES ALLOY UNS-S30300 PER ASTM-A582. PASSIVATE PER QQ-P-35.
CONTACT:	BeCu UNS-C17300 PER ASTM-B-196/197 GOLD PLATE PER MIL-G-45204
DIELECTRIC INSULATOR:	VIRGIN TFE FLUOROCARBON PER ASTM-D-1710 AND ASTM-D-1457
BEAD RING:	ULTEM 1000 PER ASTM-D-5205
RETAINING RING:	BeCu UNS-C17300 PER ASTM-B-196/197
GASKET:	SILICONE RUBBER PER ZZ-R-765
MATERIAL & FINISH	

PRODUCT DESIGN SPECS.	91A58296
SPECIFICATION GROUP	DOC. No.

2. INTERFACE IN ACCORDANCE TO MIL-STD-348.
1. ALL DIMENSIONS ARE IN INCHES, ALL ANGLES ARE IN DEGREES.

NOTES: UNLESS OTHERWISE SPECIFIED

REV A	RELEASE	DATE: 5/7/04	APRVD. B.CLYATT	DATE: 5/7/04	TITLE MODEL 121-01SF SSMA PLUG .540 LONG THREAD-IN TO ACCEPT .012 DIA. PIN
 Southwest Microwave, Inc. 9055 South McKemy Street Tempe, Arizona 85284-2946 Telephone (480) 783-0201 Fax (480) 783-0360					DRN BY: EJO DATE: 4/04 SCALE: 3:1 SHEET: 1 OF 1
					DWG. NO. 79A58224 REV. A