

NOTE: Information herein is believed by Southwest Microwave, Inc. to be accurate. However, Southwest Microwave assumes no responsibility for any omissions or errors or inaccuracies for its use or for any infringements of patents or other rights of third parties that may result from its use. Data is intended for informational purpose only and does not constitute a contract of sale or any express or implied warranty, including any warranty of merchant ability or fitness for a particular purpose.

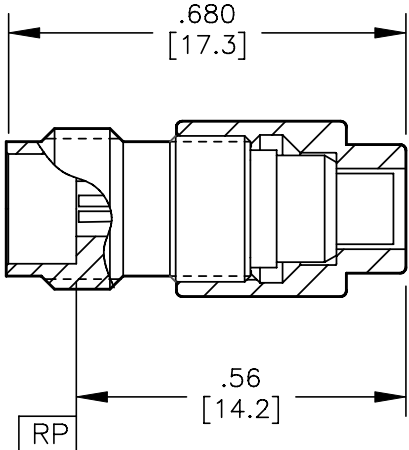
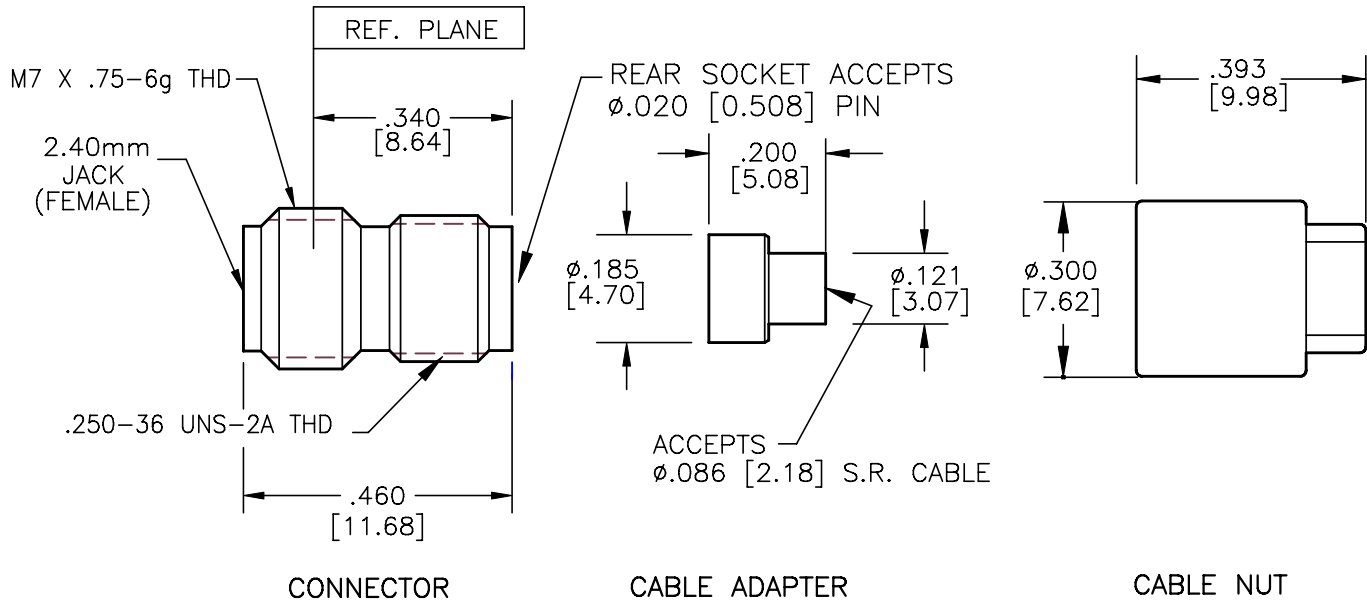

HOUSING:	STEEL, CRES ALLOY UNS-S30300 PER ASTM-A582. PASSIVATE PER ASTM-A967-99
CONTACT:	BeCu UNS-C17300 PER ASTM-B-196/197 GOLD PLATE PER MIL-G-45204
BEAD RING:	1) KEL-F PER MIL-P-46036 2) ULTEM 1000 PER ASTM-D-5205
CABLE ADAPTER:	BRASS, COPPER ALLOY UNS#C36000 PER ASTM-B-16/249. GOLD PLATE PER MIL-G-45204
CABLE NUT:	STEEL, CRES ALLOY UNS-S30300 PER ASTM-A582. PASSIVATE PER ASTM-A967-99
ITEM	MATERIAL & FINISH

CABLE ASSY. INSTR.	91S59287
CONTACT GAGING SPEC.	91B55468
SPECIFICATIONS	91P56087
INTERFACE	91P53661
SPECIFICATION GROUP	DRAWING NO.

2. INTERFACE I.A.W. MIL-STD-348

1. ALL DIMENSIONS ARE IN INCHES, ALL ANGLES ARE IN DEGREES. DIMENSIONS SHOWN IN BRACKETS [XXX] ARE MILLIMETERS.

TOLERANCES ARE BASED UPON DIMENSIONS IN INCHES. METRIC DIMENSIONS ARE FOR "REFERENCE ONLY".

NOTES: UNLESS OTHERWISE SPECIFIED

REV B	ECN: 8358	INIT: SS	DATE: 7/21/06	APRVD. EJO	DATE: 8/2/06
-------	-----------	----------	---------------	------------	--------------



Southwest Microwave, Inc.
9055 South McKemy Street
Tempe, Arizona 85284-2946
Telephone (480) 783-0201
Fax (480) 783-0360

TITLE			
2.40 JACK CABLE CONNECTOR TO ACCEPT .086 SEMI-RIGID CABLE			
DRN BY: EJO	DATE: 2/00	MODEL NO. 1402-02SF	REV. B
SCALE: 3:1	DWG. NO. 79P56257		
SHEET: 1 OF 1			