

MODEL No.:

1412-57SF

NOTE: Information herein is believed by Southwest Microwave, Inc. to be accurate. However, Southwest Microwave assumes no responsibility for any omissions or errors or inaccuracies for its use or for any infringements of patents or other rights of third parties that may result from its use. Data is intended for informational purpose only and does not constitute a contract of sale or any express or implied warranty, including any warranty of merchant ability or fitness for a particular purpose.

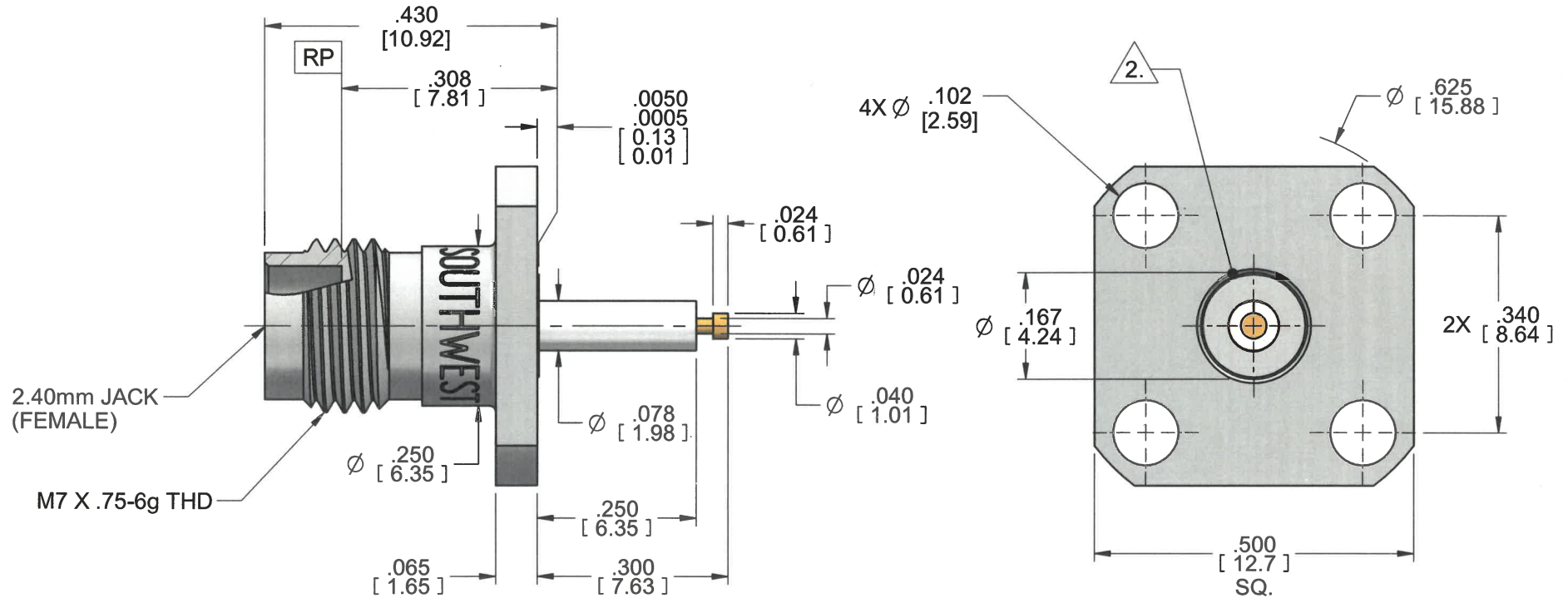

HOUSING:	STEEL, CRES ALLOY UNS-S30300 PER ASTM A582, PASSIVATED PER ASTM A967
CONTACT:	BeCu ALLOY UNS-C17300 PER ASTM B196/197. GOLD PLATE PER ASTM B488
DIELECTRIC:	VIRGIN PTFE FLUOROCARBON PER ASTM D1710, TYPE 1 GRADE 1, CLASS B
CAPTURE BEAD:	ULTEM 1000 PER ASTM D5205
ITEM	MATERIAL & FINISH

DOCUMENT CONTROL
FEB 11 2022

2. 360° RAISED METAL GROUNDING RING.

1. ALL DIMENSIONS ARE IN INCHES. ALL ANGLES ARE IN DEGREES. DIMENSIONS SHOWN IN BRACKETS [XXX] ARE IN MILLIMETERS.

NOTES: UNLESS OTHERWISE SPECIFIED.

REV A	RELEASE	APRVD. DE	DATE: 1/26/22	TITLE 2.40mm JACK, 4 HOLE 1/2"SQ., Ø.040 NAIL HEAD PROBE
 Southwest Microwave, Inc. 9055 South McKemy Street Tempe, Arizona 85284-2946 Telephone (480) 783-0201 Fax (480) 783-0360		DRN BY: DD	DATE: 12/07/21	DWG. NO. 79P69783
		SHEET: 1 OF 1		REV. A