

NOTE: Information herein is believed by Southwest Microwave, Inc. to be accurate. However, Southwest Microwave assumes no responsibility for any omissions or errors or inaccuracies for its use or for any infringements of patents or other rights of third parties that may result from its use. Data is intended for informational purpose only and does not constitute a contract of sale or any express or implied warranty, including any warranty of merchant ability or fitness for a particular purpose.

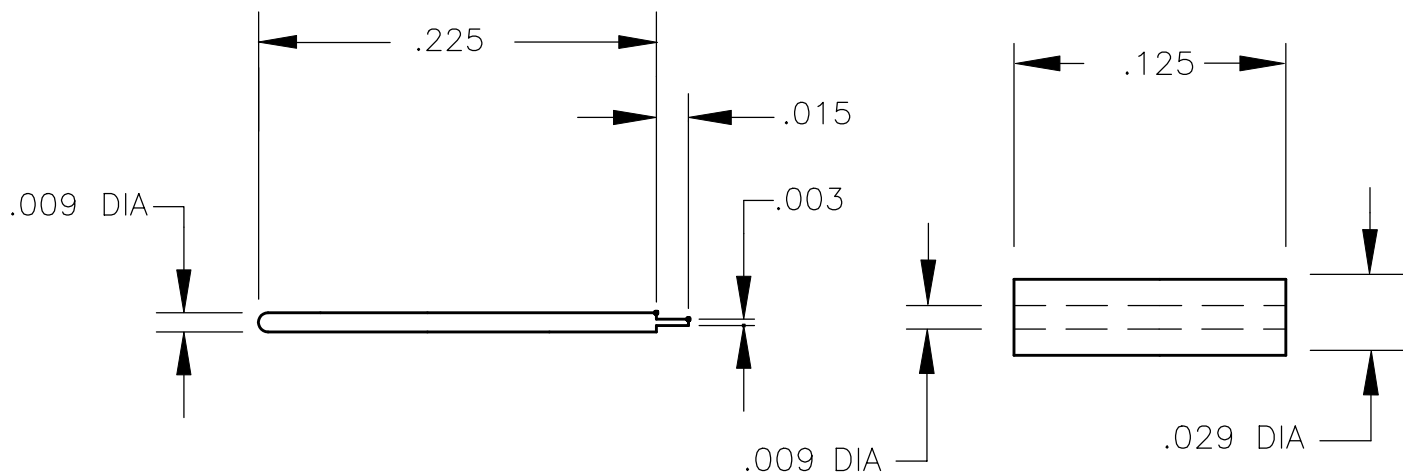

**PIN/TAB
1490-02P**

**DIELECTRIC
1490-03D**

APPLICATION

STRIPLINE TRANSITION LAUNCH

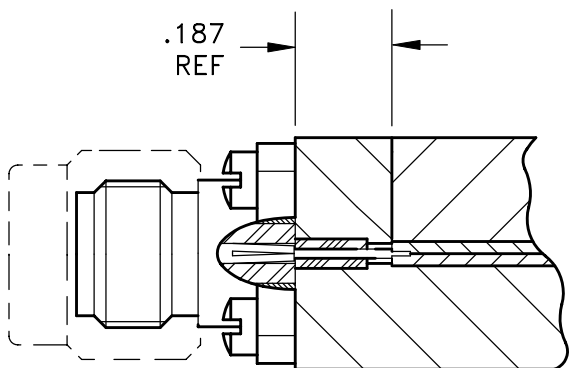

PIN/TAB BeCu
UNS-C17300 PER ASTM-B-196/197.
GOLD PLATE PER MIL-G-45204.

DIEL: VIRGIN TFE FLUOROCARBON PER
ASTM-D-1710, AND ASTM-D-1457.

MATERIAL & FINISH

DRAWN SS	DATE 9/11/01	APRVD. BL	DATE 9/28/01
--------------------	------------------------	---------------------	------------------------



Southwest Microwave, Inc.
9055 South McKemy Street
Tempe, Arizona 85284-2946
Telephone (480) 783-0201
Fax (480) 783-0360

A	RELEASE	9/28/01	BL
REV.	ECN	DESCRIPTION	DATE APPVD

TITLE 1490-02P-03D
PIN/TAB (.009) DIA X .225 LONG .015 TAB
WITH .125 LONG DIELECTRIC

SCALE NONE	DWG. NO.	REV.
SHEET 1 OF 1	79P57126	A