

NOTE: Information herein is believed by Southwest Microwave, Inc. to be accurate. However, Southwest Microwave assumes no responsibility for any omissions or errors or inaccuracies for its use or for any infringements of patents or other rights of third parties that may result from its use. Data is intended for informational purpose only and does not constitute a contract of sale or any express or implied warranty, including any warranty of merchant ability or fitness for a particular purpose.

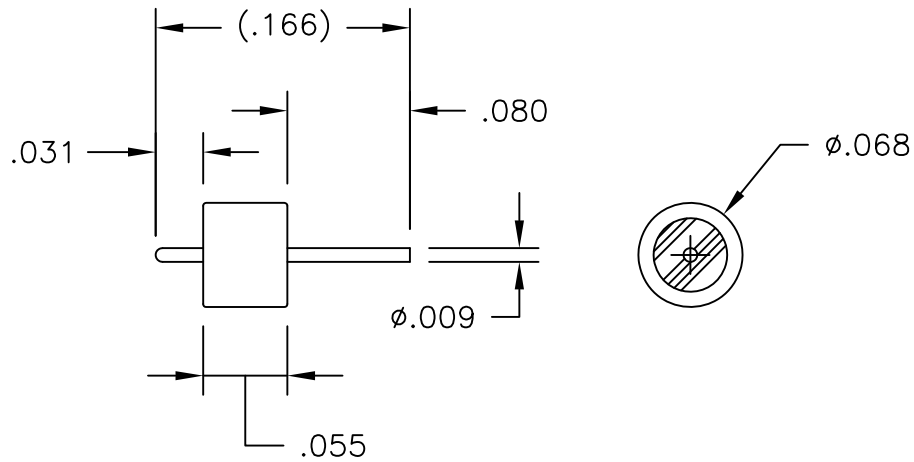

NOTES:

1. IMPEDANCE 50 OHMS NOMINAL.
2. METAL PARTS: KOVAR.
3. PLATING: GOLD OVER NICKEL PER MIL-G-45204.
4. 7070 GLASS.

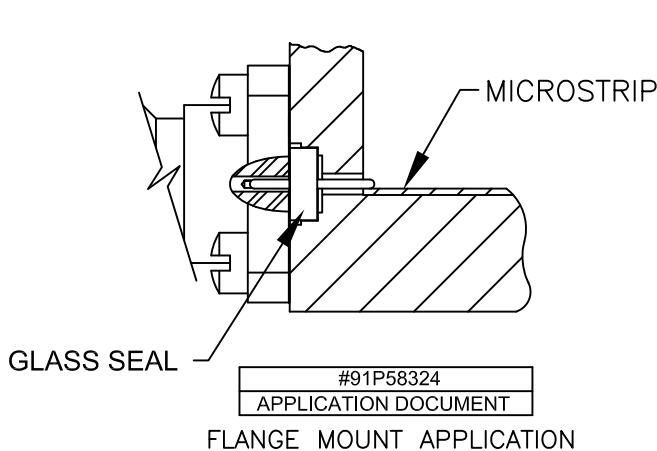

FLANGE MOUNT APPLICATION

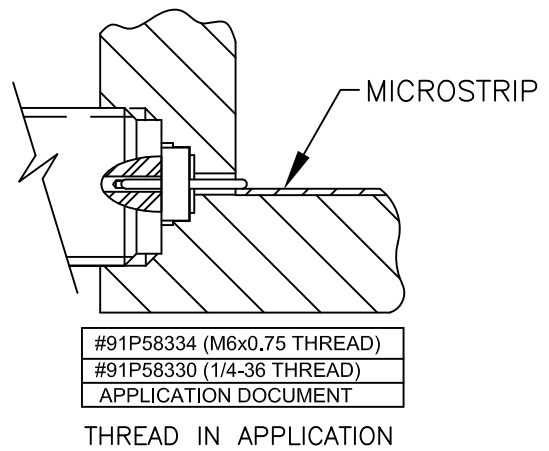

THREAD IN APPLICATION

APPLICATION REFERENCE
N.T.S.

REV A2	ECN: 8761	INIT: EJO	DATE: 3/20/09	APRVD. BR	DATE: 4/15/09	TITLE 50 OHM GLASS SEAL .068D x .055 EYELET, .009D x .205L C/C												
 <p>Southwest Microwave, Inc. 9055 South McKemy Street Tempe, Arizona 85284-2946 Telephone (480) 783-0201 Fax (480) 783-0360</p>						<table border="1"> <tr> <td>DRN BY: EJO</td> <td>DATE: 6/03</td> <td>MODEL NO. 1490-14G</td> <td>REV. A₂</td> </tr> <tr> <td colspan="2">SCALE: N/A</td> <td>DWG. NO. 79P57887</td> <td></td> </tr> <tr> <td colspan="3">SHEET: 1 OF 1</td> <td></td> </tr> </table>	DRN BY: EJO	DATE: 6/03	MODEL NO. 1490-14G	REV. A ₂	SCALE: N/A		DWG. NO. 79P57887		SHEET: 1 OF 1			
DRN BY: EJO	DATE: 6/03	MODEL NO. 1490-14G	REV. A ₂															
SCALE: N/A		DWG. NO. 79P57887																
SHEET: 1 OF 1																		