

MODEL No.:

17502-4002P

NOTE: Information herein is believed by Southwest Microwave, Inc. to be accurate. However, Southwest Microwave assumes no responsibility for any omissions or errors or inaccuracies for its use or for any infringements of patents or other rights of third parties that may result from its use. Data is intended for informational purpose only and does not constitute a contract of sale or any express or implied warranty, including any warranty of merchant ability or fitness for a particular purpose.

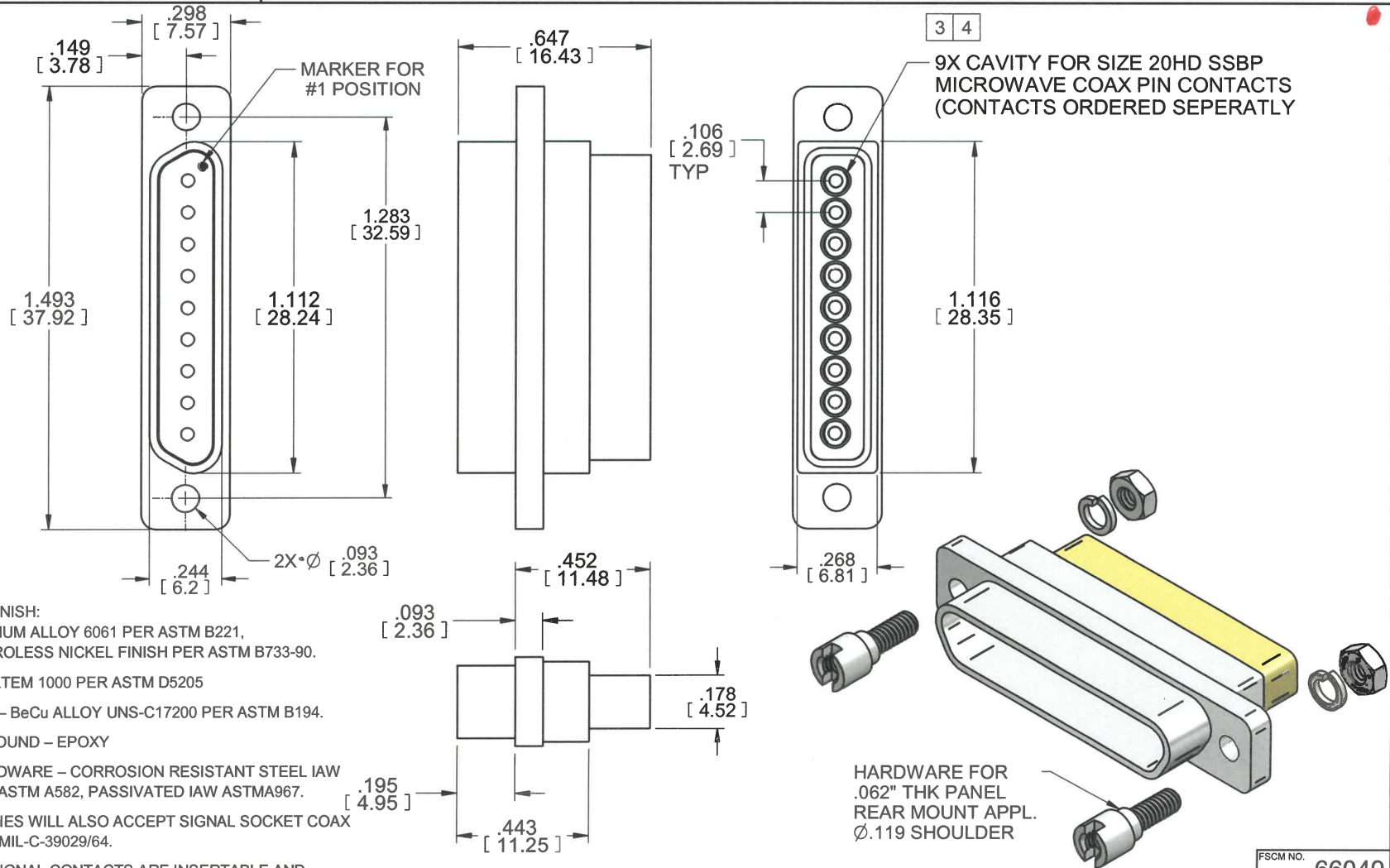

5. MATERIAL AND FINISH:

SHELL – ALUMINUM ALLOY 6061 PER ASTM B221,
ELECTROLESS NICKEL FINISH PER ASTM B733-90.

INSULATOR – ULTEM 1000 PER ASTM D5205

RETAING CLIPS – BeCu ALLOY UNS-C17200 PER ASTM B194.

POTTING COMPOUND – EPOXY

MOUNTING HARDWARE – CORROSION RESISTANT STEEL IAW
ASTM A484 AND ASTM A582, PASSIVATED IAW ASTM A967.

4. CONTACT CAVITIES WILL ALSO ACCEPT SIGNAL SOCKET COAX CONTACTS PER MIL-C-39029/64.

3. ALL SSBP AND SIGNAL CONTACTS ARE INSERTABLE AND REMOVEABLE USING STANDARD M81969/39-01 INSERTION/EXTRACTION TOOL.

2. EXTERNAL CONFIG. I.A.W. MIL-DTL-83513

1. ALL DIMENSIONS ARE IN INCHES. ALL ANGLES ARE IN DEGREES. DIMENSIONS SHOWN IN BRACKETS [XXX] ARE IN MILLIMETERS.

NOTES: UNLESS OTHERWISE SPECIFIED.

HARDWARE FOR
.062" THK PANEL
REAR MOUNT APPL.
Ø.119 SHOULDER

FSCM NO. 66049

REV B	ECN: 9610	DATE: 3/16/17	APRVD <i>[Signature]</i>	DATE: 3/21/17
----------	-----------	------------------	-----------------------------	------------------



Southwest Microwave, Inc.
9055 South McKemy Street
Tempe, Arizona 85284-2946
Telephone (480) 783-0201
Fax (480) 783-0360

TITLE
MICRO-D RECEPTACLE 9 POSITION
FOR SIZE 20HD SSBP COAX PIN
CONTACTS

DRN BY: E. OLSEN	DATE: 10/2/14	MODEL NO. 17502-4002P	REV. B
SCALE: 2:1		DWG. NO. 79BP61837	
SHEET: 1 OF 1			

MPD-A-0-L-3x