

MODEL No.:

1830-02SF

NOTE: Information herein is believed by Southwest Microwave, Inc. to be accurate. However, Southwest Microwave assumes no responsibility for any omissions or errors or inaccuracies for its use or for any infringements of patents or other rights of third parties that may result from its use. Data is intended for informational purpose only and does not constitute a contract of sale or any express or implied warranty, including any warranty of merchant ability or fitness for a particular purpose.

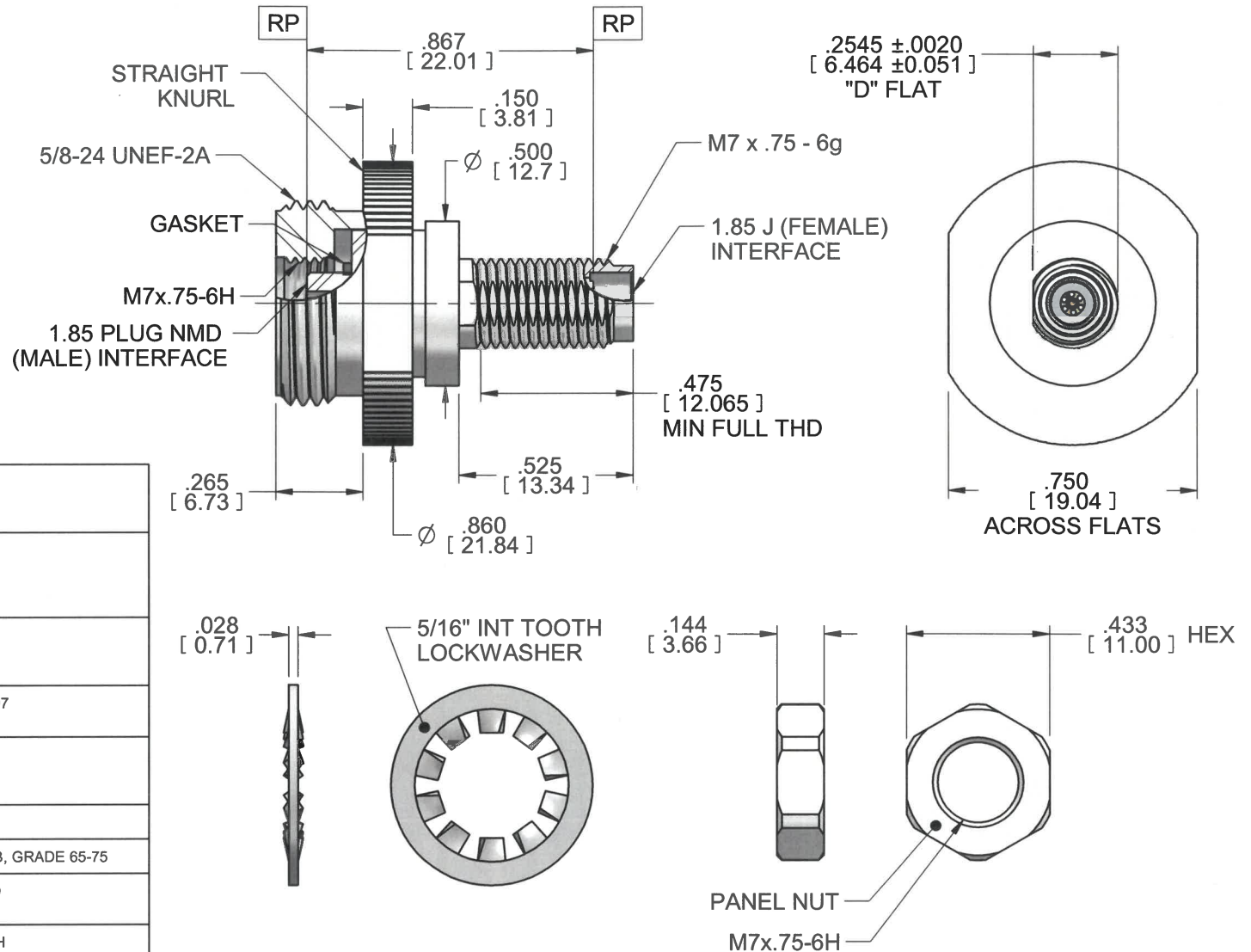
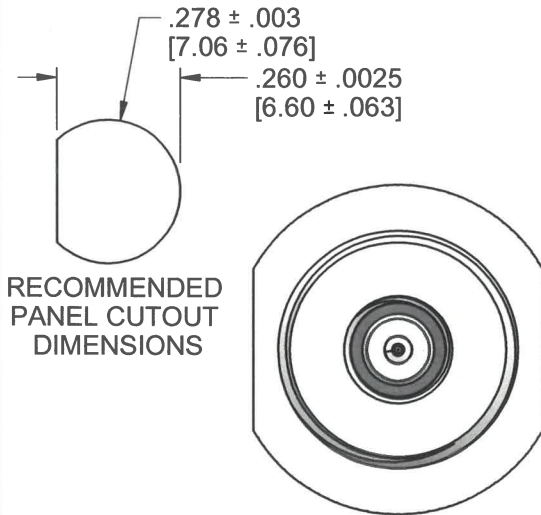

PANEL NUT:	STEEL, CRES ALLOY UNS-S30300 PER ASTM A582 PASSIVATED PER ASTM A967
LOCK WASHER:	STEEL, CRES ALLOY UNS-S30300 OR UNS-S30400 OR STEEL ALLOY UNS-S41000 PASSIVATED PER ASTM A967
HOUSING:	STEEL, CRES ALLOY UNS-S30300 PER ASTM A582 PASSIVATED PER ASTM A967
CONTACT:	BeCu UNS-C17300 PER ASTM B196/197 GOLD PLATE PER ASTM B488
SUPPORT BEAD:	VIRGIN PTFE FLUOROCARBON PER ASTM D1710, TYPE 1 GRADE 1, CLASS B
CAPTURE BEAD:	ULTEM 1000 PER ASTM D5205
GASKET	SILICON RUBBER ZZ-R-765 CLASS II B, GRADE 65-75
RETAINING RING:	PHOSPHOR BRONZE PER ASTM B159 TEMPER:SPRING
ITEM	MATERIAL & FINISH

1. ALL DIMENSIONS ARE IN INCHES. ALL ANGLES ARE IN DEGREES. DIMENSIONS SHOWN IN BRACKETS [XXX] ARE IN MILLIMETERS.

NOTES: UNLESS OTHERWISE SPECIFIED.

REV A	RELEASE	APRVD DE	DATE 10/1/21	TITLE 1830-02SF 1.85 J TO 1.85 P NMD BLKHD ADP
 Southwest Microwave, Inc. 9055 South McKerny Street Tempe, Arizona 85284-2946 Telephone (480) 783-0201 Fax (480) 783-0360		DRN BY: JW	DATE: 09/21/17	DWG. NO. 79R63821
		SCALE: 2:1		
		SHEET: 1 OF 1		REV. A