

MODEL No:

1893-0XA-7

NOTE: Information herein is believed by Southwest Microwave, Inc. to be accurate. However, Southwest Microwave assumes no responsibility for any omissions or errors or inaccuracies for its use or for any infringements of patents or other rights of third parties that may result from its use. Data is intended for informational purpose only and does not constitute a contract of sale or any express or implied warranty, including any warranty of merchant ability or fitness for a particular purpose.

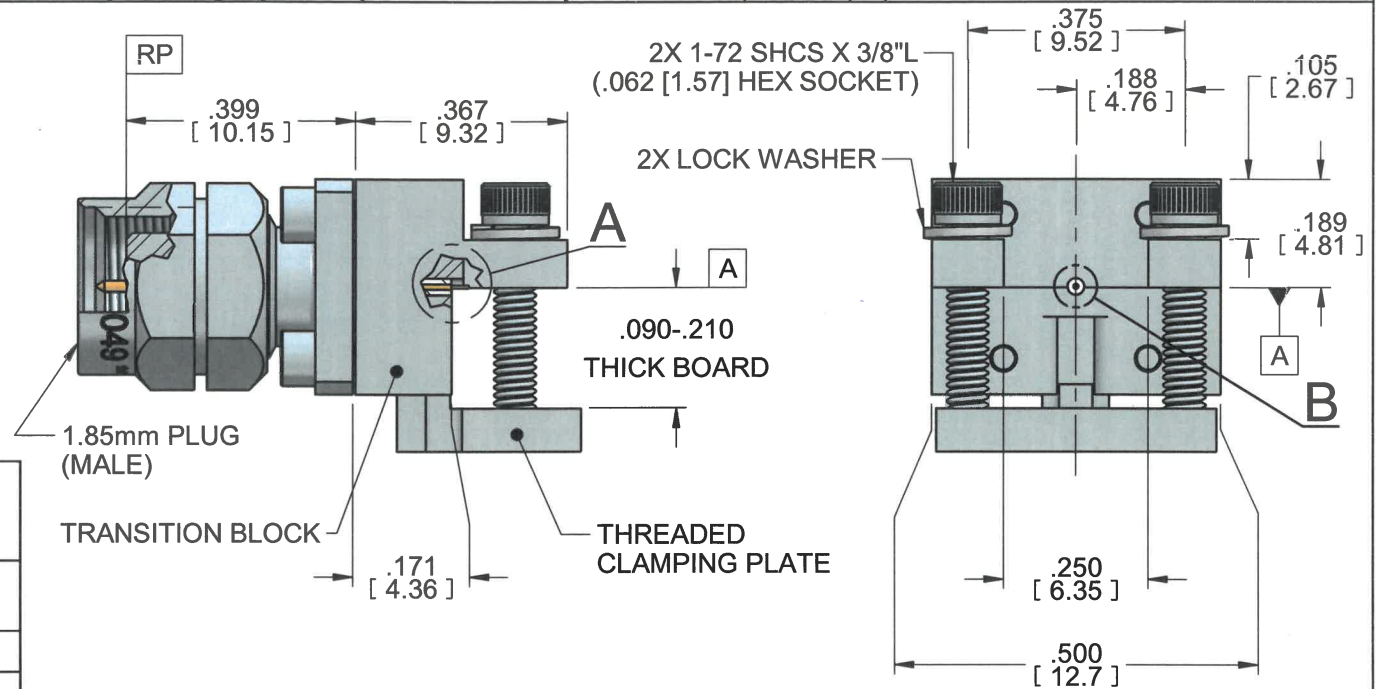
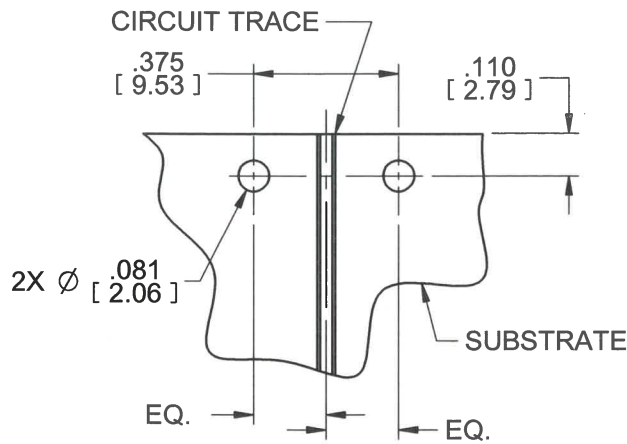

HOUSING & COUPLING NUT:	STEEL, CRES ALLOY UNS 30300 PER ASTM A582 PASSIVATED PER ASTM A967
CONTACT:	BeCu UNS C17300 PER ASTM B196 GOLD PLATE PER ASTM B488
CAPTURE BEAD:	ULTEM 1000 PER ASTM D5205
BEAD:	VIRGIN PTFE FLUOROCARBON PER ASTM D1710, TYPE 1 GRADE 1, CLASS B
RETAINING RING:	BeCu UNS-C17200 PER ASTM B194 OR ASTM B197
GASKET	SILICONE RUBBER PER ZZ-R-765
ITEM	MATERIAL & FINISH
1.85mm CONNECTOR	

DOCUMENT CONTROL
DEC 03 2021

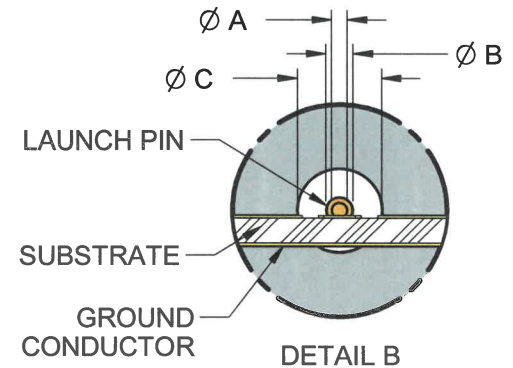
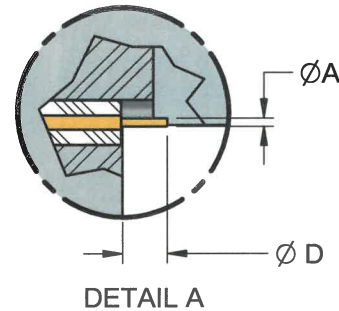

TRANSITION BLOCK, THREADED CLAMPING PLATE:	C360 BRASS ALLOY UNS C36000 PER ASTM B16. NICKEL PLATE PER AMS 2404
LAUNCH PIN:	BeCu UNS C17300 PER ASTM B196 GOLD PLATE PER MIL-DTL-45204
TRANSITION BLOCK DIELECTRIC:	VIRGIN PTFE FLUOROCARBON PER ASTM D1710, TYPE 1 GRADE 1, CLASS B
ITEM	MATERIAL & FINISH
TRANSITION BLOCK	

Model	Ø A	Ø B	Ø C	D
1893-03A-7	.007	.012	.0390	.030
1893-04A-7	.005	.009	.0290	.030

REV A	RELEASE	APPRVD <i>JE</i>	DATE: 12/2/21
-------	---------	---------------------	------------------



Southwest Microwave, Inc.
9055 South McKemy Street
Tempe, Arizona 85284-2946
Telephone (480) 783-0201
Fax (480) 783-0360

1.85mm PLUG (MALE) END LAUNCH CONNECTOR (LOW PROFILE THICK BOARD .210)		
DRN BY: JAC	DATE: 12/01/21	DWG. NO. 91Y69780
SHEET: 1 OF 1		REV. A

1. ALL DIMENSIONS ARE IN INCHES. ALL ANGLES ARE IN DEGREES. DIMENSIONS SHOWN IN BRACKETS [XXX] ARE IN MILLIMETERS.

NOTES: UNLESS OTHERWISE SPECIFIED.