

NOTE: Information herein is believed by Southwest Microwave, Inc. to be accurate. However, Southwest Microwave assumes no responsibility for any omissions or errors or inaccuracies for its use or for any infringements of patents or other rights of third parties that may result from its use. Data is intended for informational purpose only and does not constitute a contract of sale or any express or implied warranty, including any warranty of merchant ability or fitness for a particular purpose.

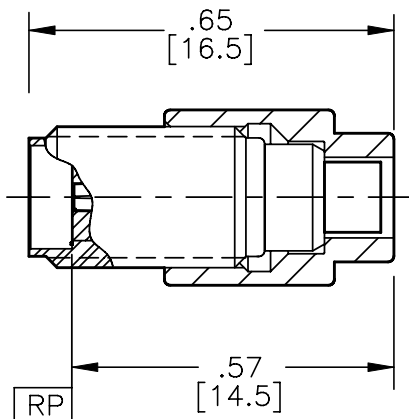
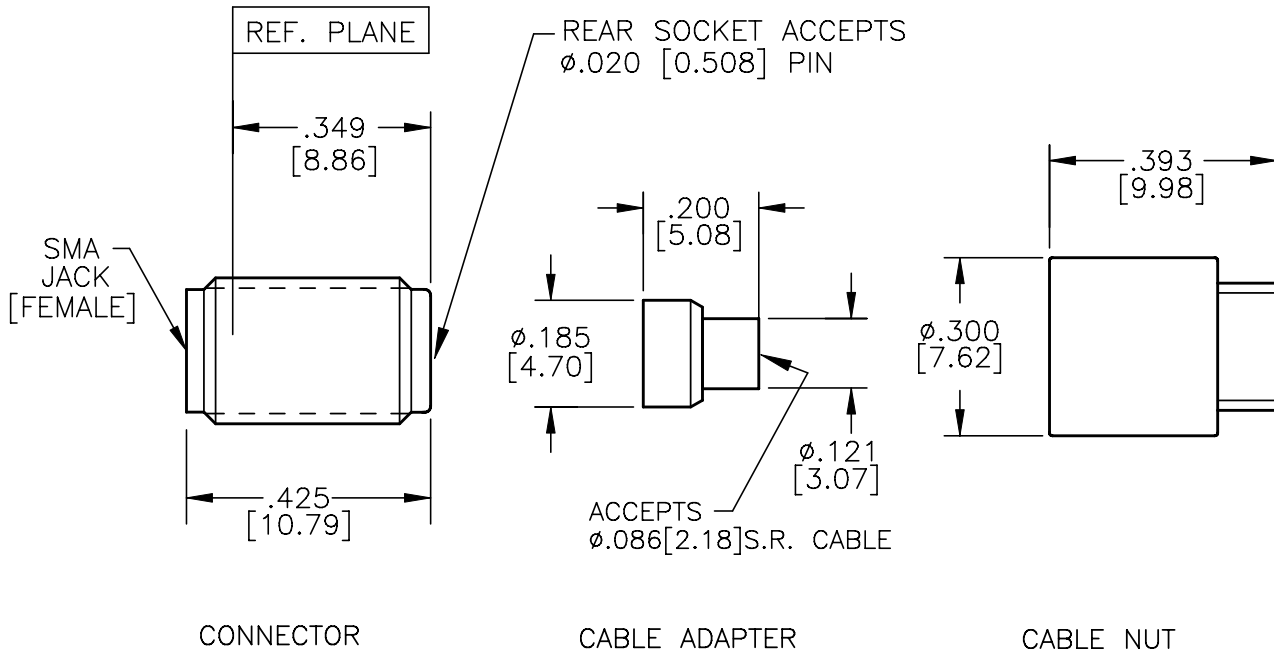

HOUSING:	STEEL, CRES ALLOY UNS-S30300 PER ASTM-A582. PASSIVATE PER ASTM-A967-99
CONTACT:	BeCu UNS-C17300 PER ASTM-B-196/197 GOLD PLATE PER MIL-G-45204
DIELECTRIC:	VIRGIN TFE FLUOROCARBON PER ASTM-D-1710 AND ASTM-D-1457
BEAD RING:	ULTEM 1000 PER ASTM-D-5205
CABLE ADAPTER:	BRASS, COPPER ALLOY UNS#C36000 PER ASTM-B-16/249. GOLD PLATE PER MIL-G-45204
CABLE NUT:	STEEL, CRES ALLOY UNS-S30300 PER ASTM-A582. PASSIVATE PER ASTM-A967-99
ITEM	MATERIAL & FINISH

CABLE ASSY. INSTR.	91S59287
SPECIFICATIONS	91B52088
INTERFACE	91B56188
SPECIFICATION GROUP	DRAWING NO.

2. INTERFACE I.A.W. MIL-STD-348

1. ALL DIMENSIONS ARE IN INCHES, ALL ANGLES ARE IN DEGREES. DIMENSIONS SHOWN IN BRACKETS [XXX] ARE MILLIMETERS.

TOLERANCES ARE BASED UPON DIMENSIONS IN INCHES. METRIC DIMENSIONS ARE FOR "REFERENCE ONLY".

NOTES: UNLESS OTHERWISE SPECIFIED

REV B	ECN: 8358	INIT: SS	DATE: 7/14/06	APRVD. EJO	DATE: 8/2/06	TITLE SMA JACK CABLE CONNECTOR TO ACCEPT .086 SEMI-RIDID CABLE				
 <p>Southwest Microwave, Inc. 9055 South McKemy Street Tempe, Arizona 85284-2946 Telephone (480) 783-0201 Fax (480) 783-0360</p>						DRN BY: EJO	DATE: 4/02	MODEL NO. 202-502SF	REV. B	
						SCALE: 3:1		DWG. NO. 79B55503		
						SHEET: 1 OF 1				