

DWG No.:

91B60806

NOTE: Information herein is believed by Southwest Microwave, Inc. to be accurate. However, Southwest Microwave assumes no responsibility for any omissions or errors or inaccuracies for its use or for any infringements of patents or other rights of third parties that may result from its use. Data is intended for informational purpose only and does not constitute a contract of sale or any express or implied warranty, including any warranty of merchant ability or fitness for a particular purpose.

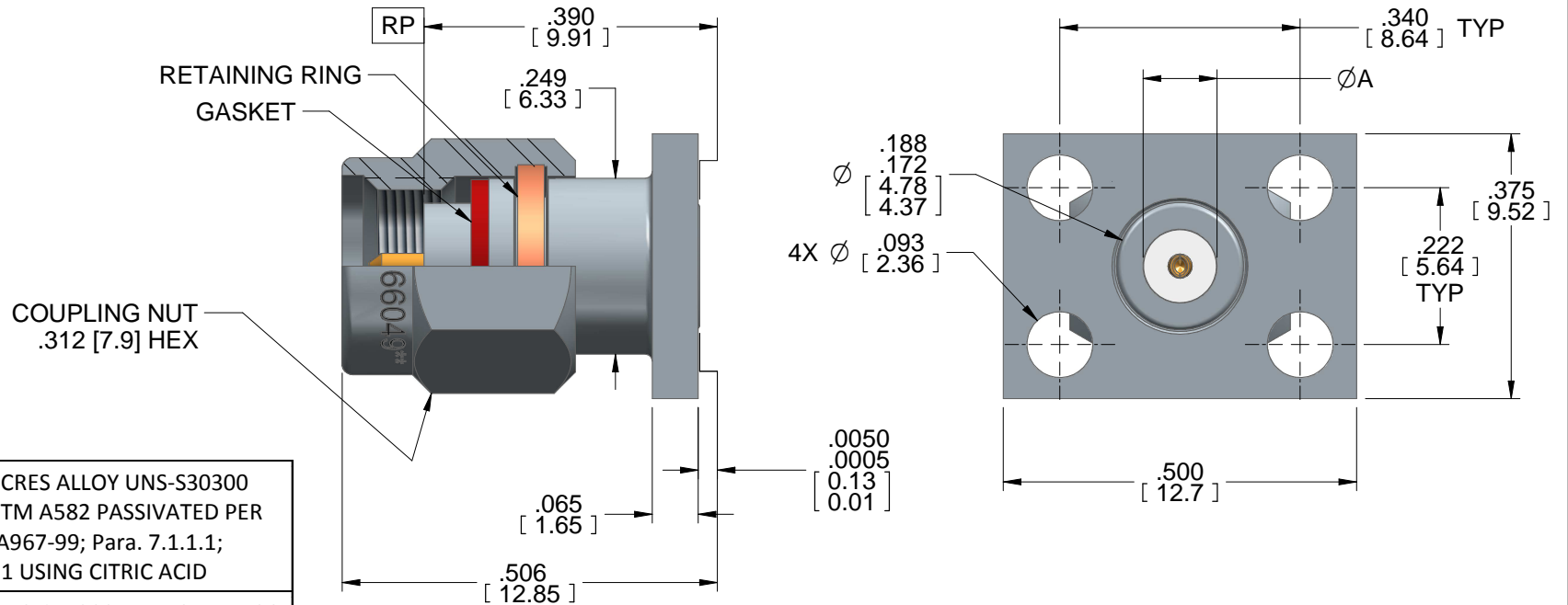

HOUSING AND COUPLING NUT:	STEEL, CRES ALLOY UNS-S30300 PER ASTM A582 PASSIVATED PER ASTM A967-99; Para. 7.1.1.1; CITRIC 1 USING CITRIC ACID
CONTACT:	BeCu UNS-C17300 PER ASTM B196 GOLD PLATE PER MIL-DTL-45204
DIELECTRIC:	VIRGIN PTFE FLUOROCARBON PER ASTM D1710, TYPE 1 GRADE 1, CLASS B
CAPTURE BEAD:	ULTEM 1000 PER ASTM D5205
RETAINING RING:	BeCu UNS-C17200 PER ASTM B194 OR ASTM B197
GASKET:	SILICONE RUBBER PER ZZ-R-765
ITEM	MATERIAL & FINISH

Model	Pin Size	Max. Pin Depth	Ø A
211-518SF	.036	.100	.1540
211-517SF	.020	.100	.1045
211-516SF	.018	.100	.1020
211-515SF	.015	.100	.0765
211-514SF	.012	.075	.0765
211-525SF	.009	.065	.0602

2. SEE 91B60792 FOR PRODUCT SPECIFICATIONS.

1. ALL DIMENSIONS ARE IN INCHES. ALL ANGLES ARE IN DEGREES. DIMENSIONS SHOWN IN BRACKETS [XXX] ARE IN MILLIMETERS.

NOTES: UNLESS OTHERWISE SPECIFIED.

REV A	RELEASE	APRVD. PLC	DATE: 5/1/12	TITLE SMA Plug (Male) 1/2" X 3/8" Flange		
 SOUTHWEST MICROWAVE		Southwest Microwave, Inc. 9055 South McKemy Street Tempe, Arizona 85284-2946 Telephone (480) 783-0201 Fax (480) 783-0360		DRN BY: EAG	DATE: 4/18/12	REV. A
				DWG. NO. 91B60806		SHEET: 1 OF 1