

MODEL No.:

2270-07G

NOTE: Information herein is believed by Southwest Microwave, Inc. to be accurate. However, Southwest Microwave assumes no responsibility for any omissions or errors or inaccuracies for its use or for any infringements of patents or other rights of third parties that may result from its use. Data is intended for informational purpose only and does not constitute a contract of sale or any express or implied warranty, including any warranty of merchant ability or fitness for a particular purpose.

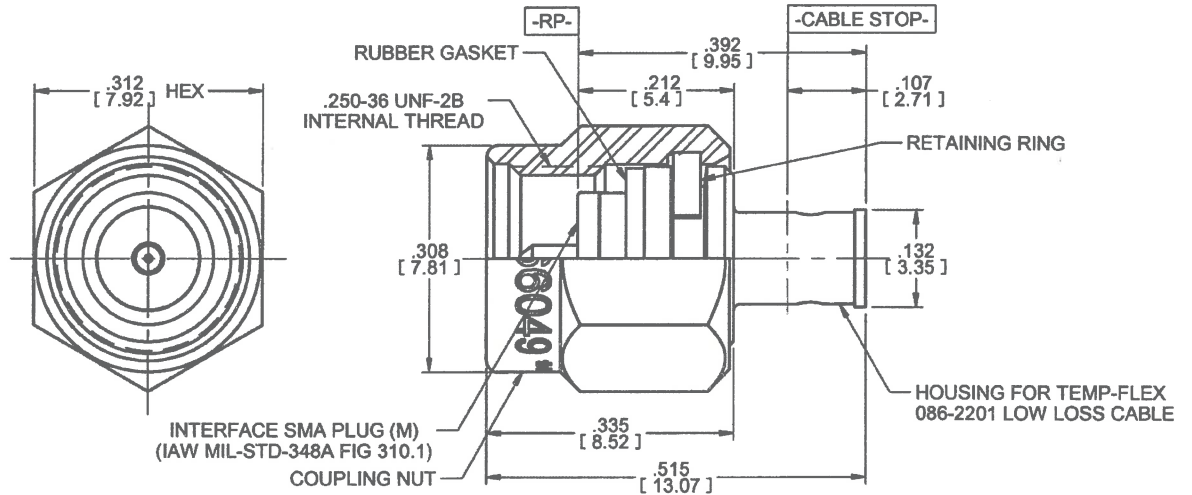

6. PERFORMANCE IS DEPENDENT UPON THE SPECIFIC CABLE SELECTED AND THIRD-PARTY CABLE PREPARATION BEYOND THE CONTROL OF SOUTHWEST MICROWAVE.

5. FOR SPECIFICATIONS SEE SPECIFICATION SHEET 91BV61132.

4. CABLE TERMINATION INSTRUCTION SPEC. 91S61015.

3. MATERIAL AND FINISH:

3.1 MATERIALS:

- 3.1.1 CENTER CONTACT, RETAINING RING: BeCu ALLOY.
- 3.1.2 HOUSING, BUSHING: BRASS ALLOY.
- 3.1.3 DIELECTRICS: HIGH TEMPERATURE POLYMER.
- 3.1.4 COUPLING NUT: STAINLESS STEEL.
- 3.1.5 BEAD RING: ULTEM 1000 PER ASTM D5205.
- 3.1.6 GASKET: SILICONE RUBBER.

3.2 FINISHES

- 3.2.1 CENTER CONTACT, HOUSING AND BUSHING: GOLD PLATE.
- 3.2.2 COUPLING NUT: PASSIVATE.

2. CONNECTOR DESIGN IS COMPATIBLE WITH CURRENT MATERIAL AND PROCESS REQUIREMENTS FOR RoHS AND WEEE PER EUROPEAN COMMUNITY DIRECTIVE 2002/95/EC.

1. ALL DIMENSIONS ARE IN INCHES. ALL ANGLES ARE IN DEGREES. DIMENSIONS SHOWN IN BRACKETS [XXX] ARE IN MILLIMETERS.

NOTES: UNLESS OTHERWISE SPECIFIED.

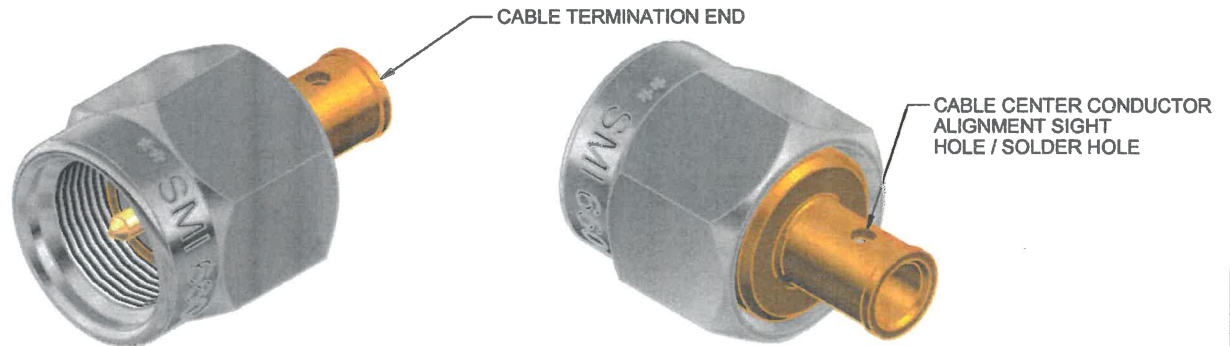

REV: A	RELEASE: SAME AS SKTC4801 REV X2	DATE: 06/18/2014	APPROV: B. Clary	DATE: 8/8/14	TITLE: SMA PLUG, DIRECT SOLDER, 086-2201 LOW LOSS CABLE
			Southwest Microwave, Inc. 9055 South McKemy Street Tempe, Arizona 85284-2946 Telephone (480) 783-0201 Fax (480) 783-0360		DRN BY: T. CLARE DATE: 01/03/13 SCALE: 4:1 SHEET: 1 OF 1
			MODEL NO. 2270-07G	REV. A	DWG. NO. 79BV61668