

NOTE: Information herein is believed by Southwest Microwave, Inc. to be accurate. However, Southwest Microwave assumes no responsibility for any omissions or errors or inaccuracies for its use or for any infringements of patents or other rights of third parties that may result from its use. Data is intended for informational purpose only and does not constitute a contract of sale or any express or implied warranty, including any warranty of merchant ability or fitness for a particular purpose.

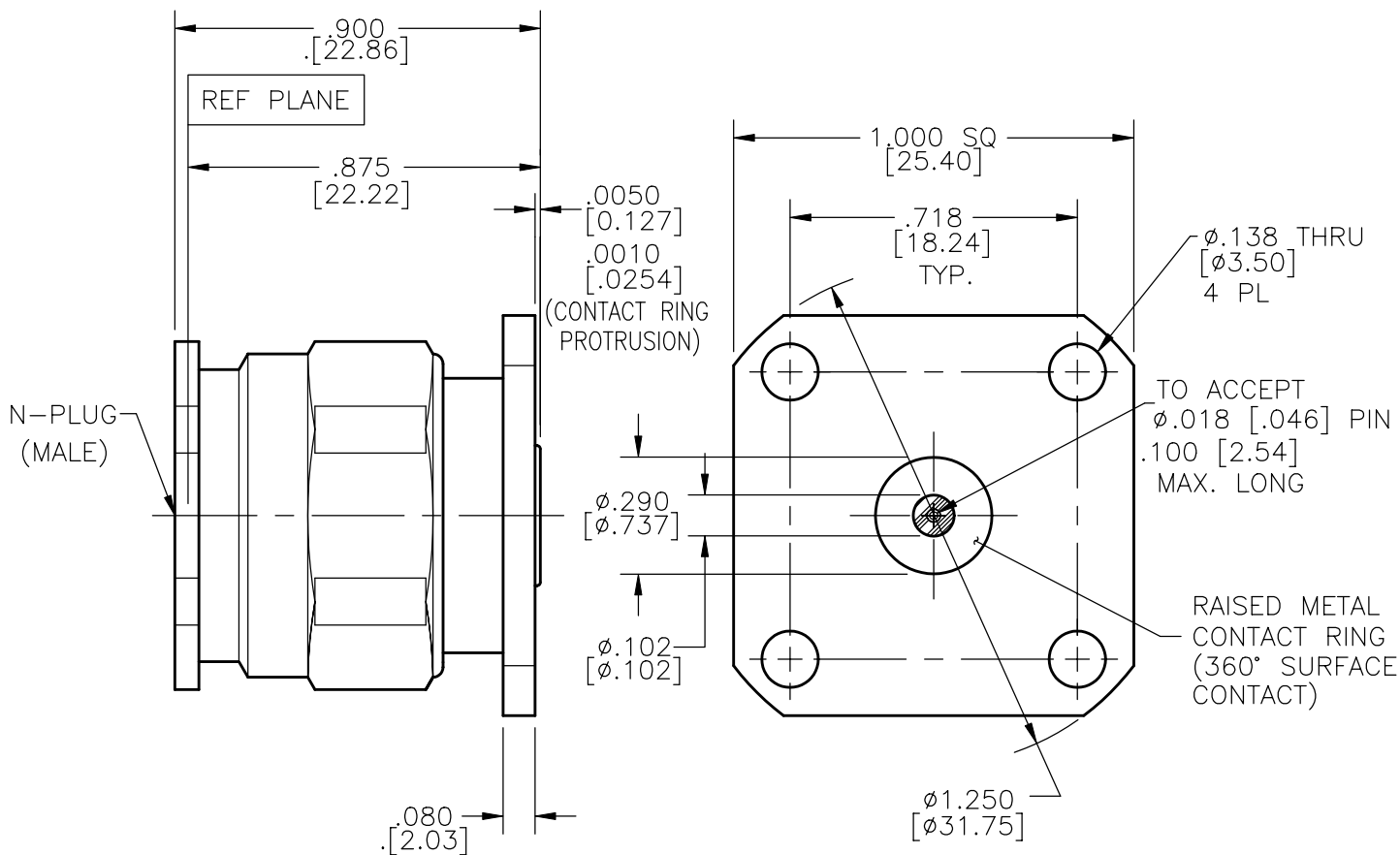

HOUSING: COUPLING NUT:	STEEL, CRES ALLOY UNS-S30300 PER ASTM-A582. PASSIVATE PER ASTM-A967-99
CONTACT:	BeCu UNS-C17300 PER ASTM-B-196/197 GOLD PLATE PER MIL-G-45204
DIELECTRIC	VIRGIN TFE FLUOROCARBON PER ASTM-D-1710 AND ASTM-D-1457
BEAD RING:	ULTEM 1000 PER ASTM-D-5205
RETAINING RING:	PHOSPHOR BRONZE PER QQ-B-746 COMP. A
GASKET:	SILICONE RUBBER PER ZZ-R-765
MATERIAL & FINISH	

2. INTERFACE I.A.W. MIL-STD-348

1. ALL DIMENSIONS ARE IN INCHES, ALL ANGLES ARE IN DEGREES. DIMENSIONS SHOWN IN BRACKETS [XXX] ARE MILLIMETERS.

TOLERANCES ARE BASED UPON DIMENSIONS IN INCHES. METRIC DIMENSIONS ARE FOR "REFERENCE ONLY".

NOTES: UNLESS OTHERWISE SPECIFIED

CONTACT GAGING SPEC.	91B52102
SPECIFICATIONS	91C59271
SPECIFICATION GROUP	DRAWING NO.

REV A	RELEASE	DATE: 6/2/06	APRVD. EJO	DATE: 6/2/06	TITLE N PLUG 4 HOLE 1.00SQ FLANGE REAR SOCKET TO ACCEPT .018 DIA PIN			
 Southwest Microwave, Inc. 9055 South McKerny Street Tempe, Arizona 85284-2946 Telephone (480) 783-0201 Fax (480) 783-0360					DRN BY: SS	DATE: 6/06	MODEL NO. 311-05SF	REV. A
					SCALE: 3:1		DWG. NO. 79C58574	
					SHEET: 1 OF 1			