

NOTE: Information herein is believed by Southwest Microwave, Inc. to be accurate. However, Southwest Microwave assumes no responsibility for any omissions or errors or inaccuracies for its use or for any infringements of patents or other rights of third parties that may result from its use. Data is intended for informational purpose only and does not constitute a contract of sale or any express or implied warranty, including any warranty of merchant ability or fitness for a particular purpose.

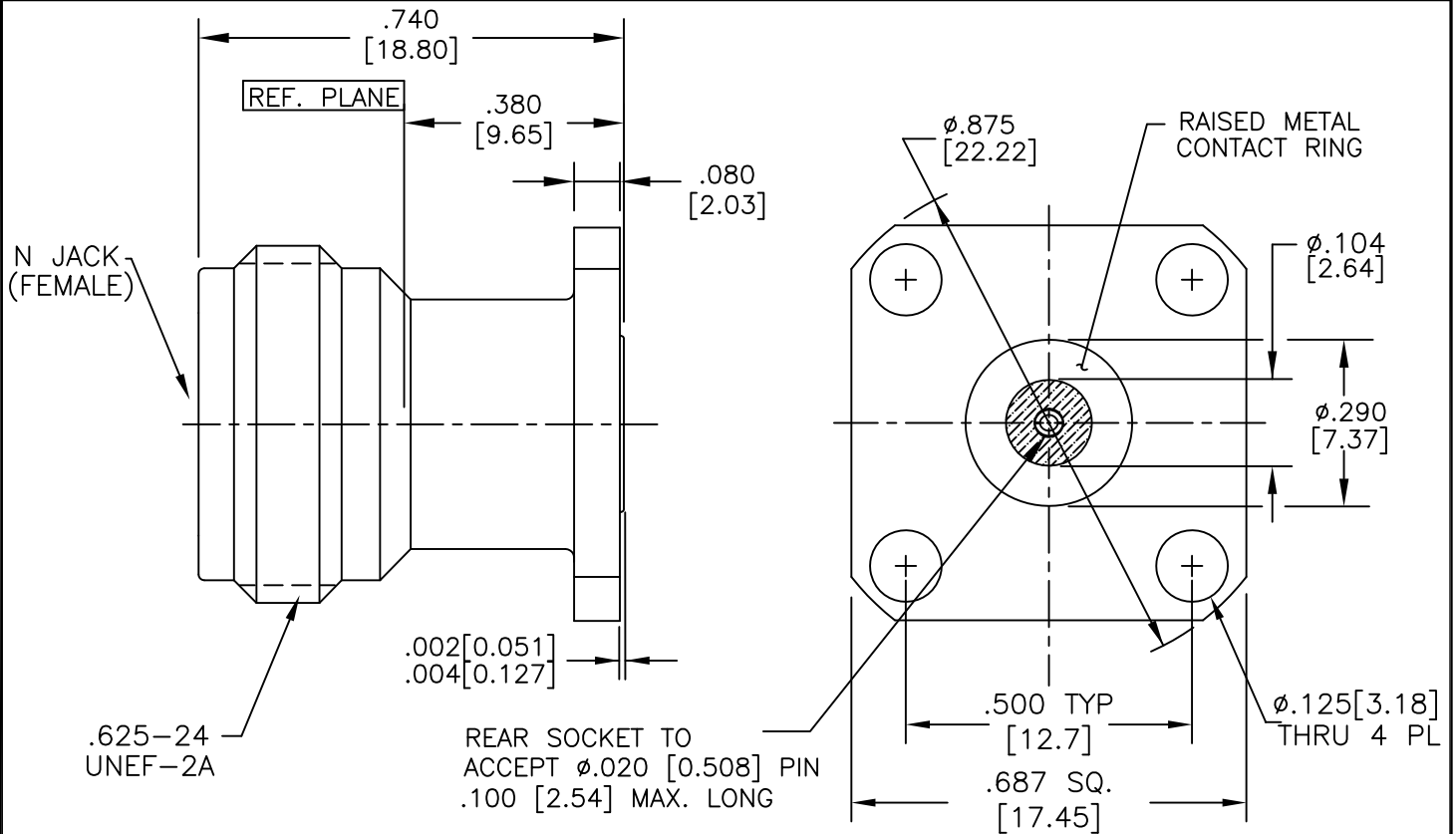

HOUSING AND METAL CONTACT RING:	STEEL, CRES ALLOY UNS-S30300 PER ASTM-A582. PASSIVATE PER QQ-P-35.
CONTACT:	BeCu UNS-C17300 PER ASTM-B-196/197 GOLD PLATE PER MIL-G-45204
DIELECTRIC INSULATOR:	VIRGIN TFE FLUOROCARBON PER ASTM-D-1710 AND ASTM-D-1457
BEAD RING:	ULTEM 1000 PER ASTM-D-5205
MATERIAL & FINISH	

2. INTERFACE I.A.W. THE REQUIREMENTS OF MIL-STD-348.

1. ALL DIMENSIONS ARE IN INCHES, ALL ANGLES ARE IN DEGREES. METRIC DIMENSIONS ARE SHOWN IN BRACKETS [MILLIMETERS].

NOTES: UNLESS OTHERWISE SPECIFIED

CONTACT GAGING SPEC. N SOCKET	91C54030
CONTACT GAGING SPEC. .020 SOCKET	91P56080
SPECIFICATIONS	91C57619
SPECIFICATION GROUP	DRAWING NO.

REV B	ECN: 8785	INIT: EAG	DATE: 5/13/09	APRVD. BR	DATE: 5/15/09	TITLE ULTEM CAPTURE N JACK 11/16SQ FLANGE TO ACCEPT (.020) DIA. PIN			
 <p>Southwest Microwave, Inc. 9055 South McKemy Street Tempe, Arizona 85284-2946 Telephone (480) 783-0201 Fax (480) 783-0360</p>						DRN BY: EJO	DATE: 8/05	MODEL NO. 312-05SF	REV. B
						SCALE: 3:1		DWG. NO. 79C58697	
						SHEET: 1 OF 1			