

NOTE: Information herein is believed by Southwest Microwave, Inc. to be accurate. However, Southwest Microwave assumes no responsibility for any omissions or errors or inaccuracies for its use or for any infringements of patents or other rights of third parties that may result from its use. Data is intended for informational purpose only and does not constitute a contract of sale or any express or implied warranty, including any warranty of merchant ability or fitness for a particular purpose.

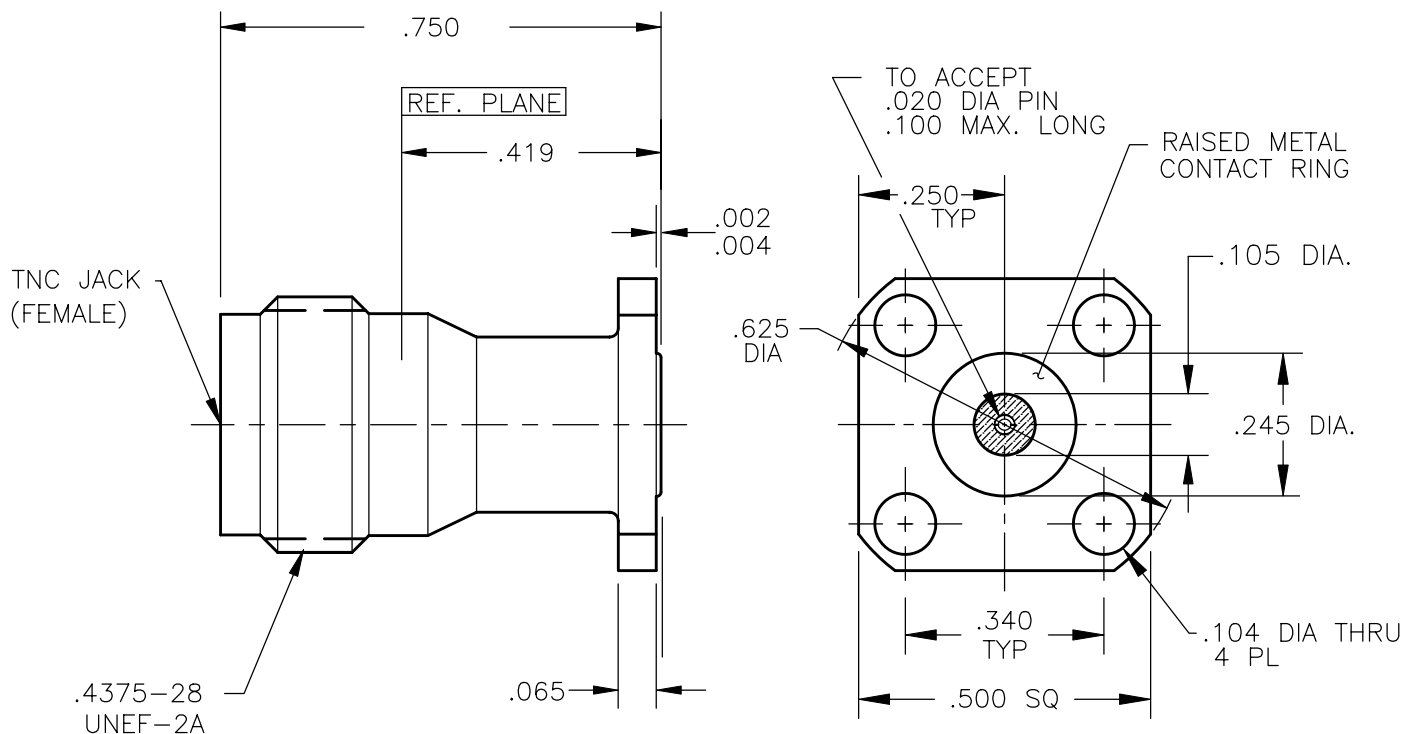

HOUSING:	STEEL, CRES ALLOY UNS-S30300 PER ASTM-A582. PASSIVATE PER QQ-P-35.
CONTACT:	BeCu UNS-C17300 PER ASTM-B-196/197 GOLD PLATE PER MIL-G-45204
DIELECTRIC INSULATOR:	VIRGIN TFE FLUOROCARBON PER ASTM-D-1710 AND ASTM-D-1457
BEAD RING:	ULTEM 1000 PER ASTM-D-5205
MATERIAL & FINISH	

CONTACT GAGING SPEC. .020 REAR SOCKET	91B52101
CONTACT GAGING SPEC. TNC SOCKET	91D52110
SPECIFICATIONS	91D52073
INTERFACE	91D52007
SPECIFICATION GROUP	DRAWING NO.

2. INTERFACE IN ACCORDANCE WITH MIL-STD-348.

1. ALL DIMENSIONS ARE IN INCHES, ALL ANGLES ARE IN DEGREES.

NOTES: UNLESS OTHERWISE SPECIFIED

REV A	RELEASE	DATE: 2/10/05	APRVD. R.BOAK	DATE: 2/10/05	TITLE	MODEL 412-31SF ULTEM CAPTURE TNC JACK 1/2SQ FLANGE TO ACCEPT .020 DIA. PIN		
 Southwest Microwave, Inc. 9055 South McKemy Street Tempe, Arizona 85284-2946 Telephone (480) 783-0201 Fax (480) 783-0360					DRN BY: EJO	DATE: 2/05	DWG. NO.	REV. A
					SCALE: 3:1	79D58376		
					SHEET: 1 OF 1			

O.L.-A-303 REV B