

MODEL No.:

50112-001P

NOTE: Information herein is believed by Southwest Microwave, Inc. to be accurate. However, Southwest Microwave assumes no responsibility for any omissions or errors or inaccuracies for its use or for any infringements of patents or other rights of third parties that may result from its use. Data is intended for informational purpose only and does not constitute a contract of sale or any express or implied warranty, including any warranty of merchant ability or fitness for a particular purpose.

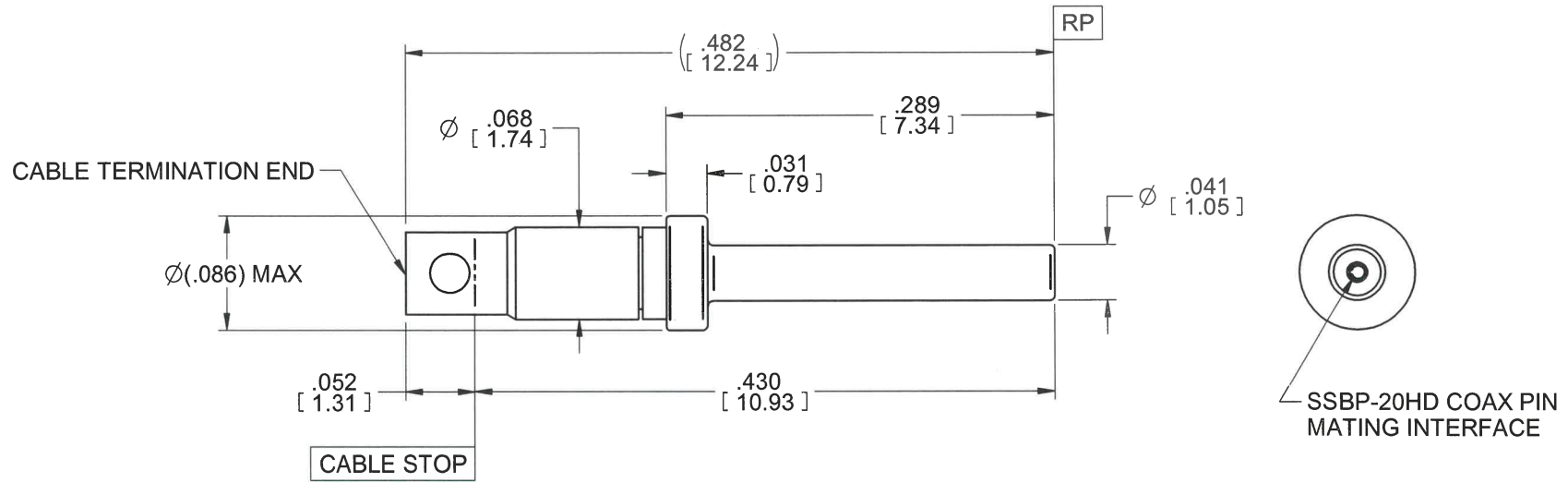

- 5. CABLE TERMINATION INSTRUCTION SPEC. 91BP60625
- 4. SPECIFICATION SHEET: 91BP61152
- 3. MATERIAL AND FINISH:

3.1 MATERIALS

- 3.1.1 CONTACTS AND BUSHINGS:
  - BeCu ALLOY

3.1.2 DIELECTRICS:

- HIGH TEMPERATURE POLYMER

3.2 FINISHES

- 3.2.1 CONTACTS AND BUSHINGS:
  - GOLD PLATE PER MIL-DTL-45204

- 2. CONNECTOR DESIGN IS COMPATIBLE WITH CURRENT MATERIAL AND PROCESS REQUIREMENTS FOR RoHS AND WEEE PER EUROPEAN COMMUNITY DIRECTIVE 2002/95/EC.

- 1. ALL DIMENSIONS ARE IN INCHES. ALL ANGLES ARE IN DEGREES. DIMENSIONS SHOWN IN BRACKETS [XXX] ARE IN MILLIMETERS.

NOTES: UNLESS OTHERWISE SPECIFIED.

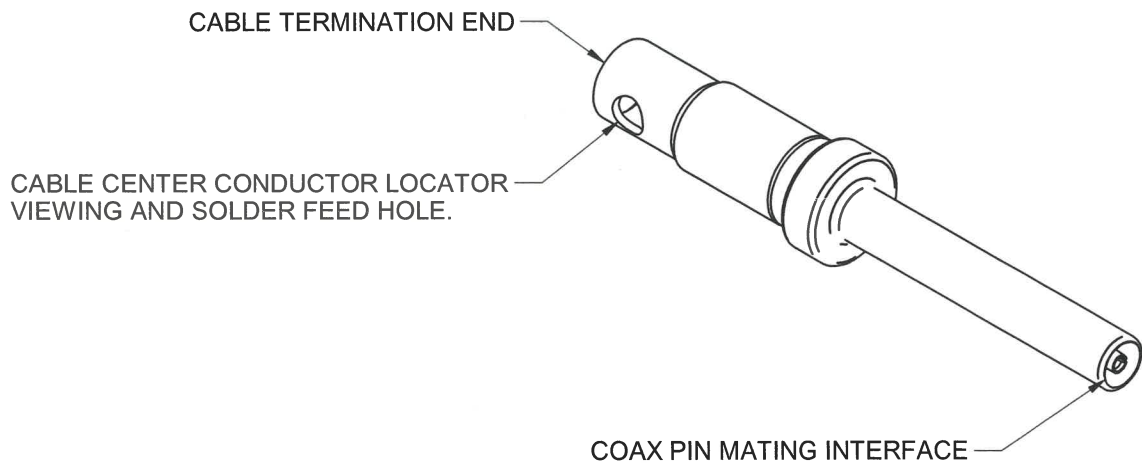

FSCM NO. 66049

REV. A	RELEASE	BY: EJO	APRVD: B. Clouth	DATE: 9/8/16	TITLE SSBP SIZE 20HD COAX PIN ASSEMBLY 047 CABLE MIL-DTL-24308		
 Southwest Microwave, Inc. 9055 South McKerny Street Tempe, Arizona 85284-2946 Telephone (480) 783-0201 Fax (480) 783-0360		DRN BY: EJO	DATE: 9/8/16	MODEL NO. 50112-001P	REV. A		
		SCALE 8:1		DWG. NO. 79BP63363			
SHEET: 1 OF 1							