

MODEL No.:

51200-002S

NOTE: Information herein is believed by Southwest Microwave, Inc., to be accurate. However, Southwest Microwave assumes no responsibility for any omissions or errors or inaccuracies for its use or for any infringements of patents or other rights of third parties that may result from its use. Data is intended for informational purpose only and does not constitute a contract of sale or any express or implied warranty, including any warranty of merchantability or fitness for a particular purpose

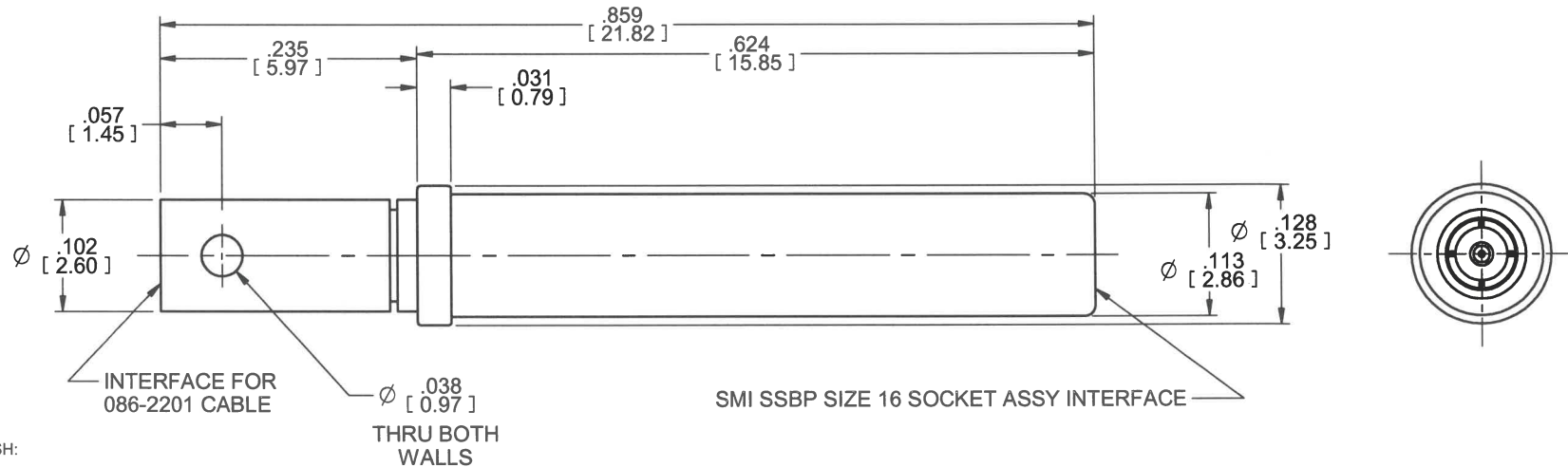

3. MATERIAL AND FINISH:

3.1 MATERIALS

OUTER AND CENTER CONTACTS, RETAINER BUSHING, AND CABLE BUSHING:
BeCu ALLOY UNS-C17300 PER ASTM B196/197

FRONT BEAD RING:
VIRGIN PTFE FLUOROCARBON PER ASTM D1710, TYPE 1, GRADE 1, CLASS B

REAR BEAD RING:
ULTEM 1000 PER ASTM D5205

FLANGED SLEEVE:
STAINLESS STEEL, UNS S17400, TEMPER A PER ASTM A564

SPRING:
STAINLESS STEEL, 304V HYTEN PER ASTM A313 (CHEM ONLY)

ALIGNMENT SLEEVE:
STAINLESS STEEL, UNS S30300, TEMPER COLD DRAWN PER ASTM A582

3.2 FINISHES

OUTER AND CENTER CONTACTS, RETAINER BUSHING, AND CABLE BUSHING:
GOLD PLATE PER MIL-DTL-45204

FLANGED AND ALIGNMENT SLEEVE:
PASSIVATE PER SMI FS-100

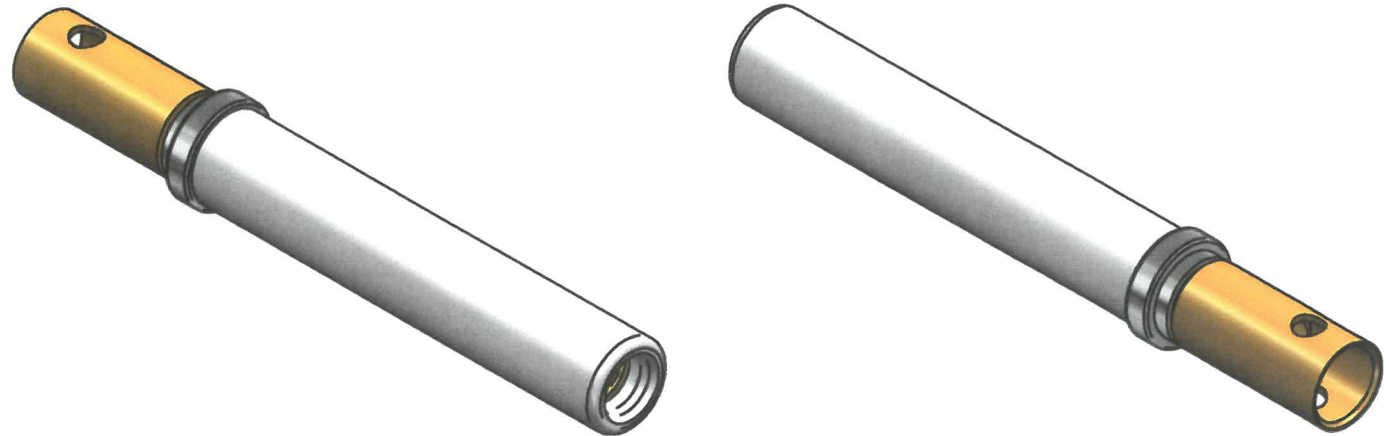

2. CONNECTOR DESIGN IS COMPATIBLE WITH CURRENT MATERIAL AND PROCESS REQUIREMENTS FOR RoHS AND WEEE PER EUROPEAN COMMUNITY DIRECTIVE 2002/95/EC.

1. ALL DIMENSIONS ARE IN INCHES. ALL ANGLES ARE IN DEGREES. DIMENSIONS SHOWN IN BRACKETS [XXX] ARE IN MILLIMETERS.

NOTES: UNLESS OTHERWISE SPECIFIED.

RELEASE	DATE:	APR.	APRVD <i>B. Clout</i>	DATE: 5/15/12	TITLE	SOCKET ASSY SSBP SIZE 16, 086-2201 CABLE D38999, SER. I, III, & IV			
 Southwest Microwave, Inc. 9055 South McKemy Street Tempe, Arizona 85284-2946 Telephone (480) 783-0201 Fax (480) 783-0360					DRN BY: D HAKE	DATE: 02/29/12	MODEL NO.	51200-002S	REV. A
					SHEET: 1 OF 1		DWG. NO.	79BP60116	