

MODEL No.:

51600-005S

NOTE: Information herein is believed by Southwest Microwave, Inc. to be accurate. However, Southwest Microwave assumes no responsibility for any omissions or errors or inaccuracies for its use or for any infringements of patents or other rights of third parties that may result from its use. Data is intended for informational purpose only and does not constitute a contract of sale or any express or implied warranty, including any warranty of merchant ability or fitness for a particular purpose.

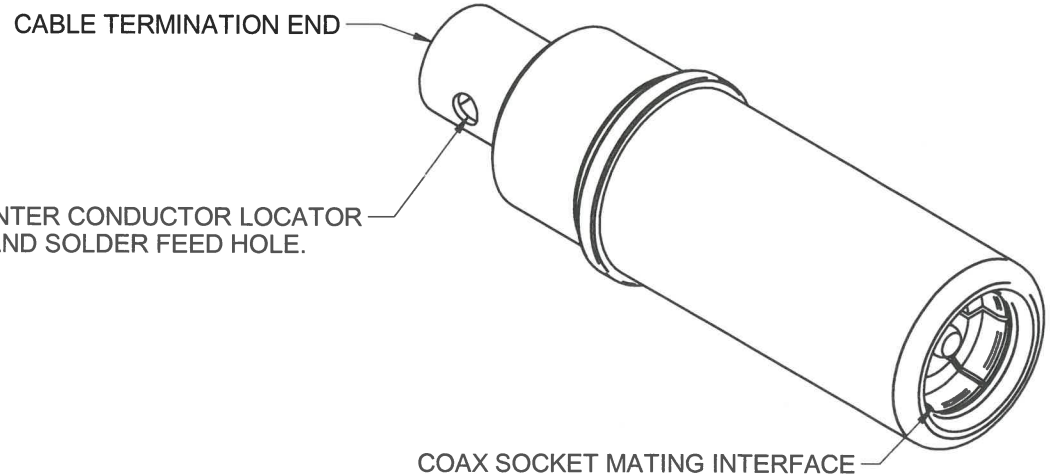
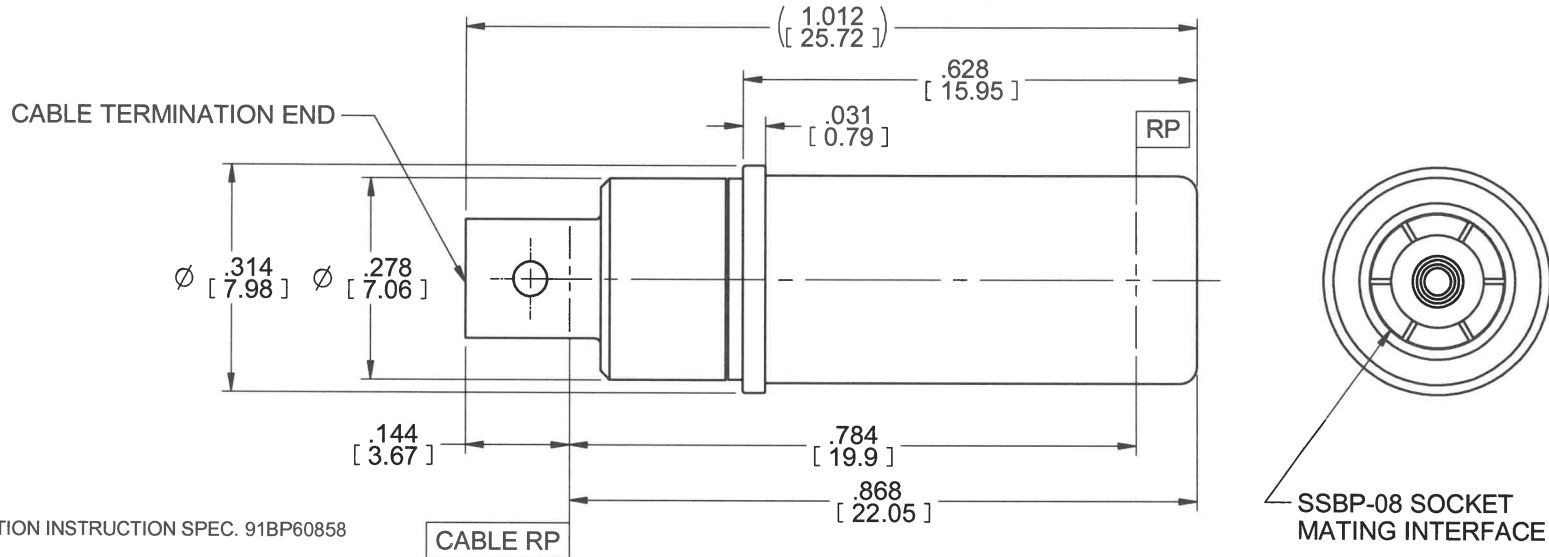

4. CABLE TERMINATION INSTRUCTION SPEC. 91BP60858

3. MATERIAL AND FINISH:

3.1 MATERIALS

3.1.1 CONTACTS AND BUSHINGS:  
- BeCu ALLOY

3.1.2 DIELECTRICS:  
- HIGH TEMPERATURE POLYMER

3.1.3 SPRING AND OUTER SLEEVE:  
- STAINLESS STEEL

3.2 FINISHES

3.2.1 CONTACTS AND BUSHINGS:  
- GOLD PLATE PER MIL-DTL-45204

3.2.2 SPRING AND OUTER SLEEVE:  
- PASSIVATE

2. CONNECTOR DESIGN IS COMPATIBLE WITH CURRENT MATERIAL AND PROCESS REQUIREMENTS FOR RoHS AND WEEE PER EUROPEAN COMMUNITY DIRECTIVE 2002/95/EC.

1. ALL DIMENSIONS ARE IN INCHES. ALL ANGLES ARE IN DEGREES. DIMENSIONS SHOWN IN BRACKETS [XXX] ARE IN MILLIMETERS.

NOTES: UNLESS OTHERWISE SPECIFIED.

REV. A	RELEASE (WAS SKDH4308 X0)	APPRVD: <i>B. Dyett</i>	DATE: 7/5/13	TITLE	SSBP SIZE 8 COAX SOCKET ASSEMBLY ECS 352001 CABLE MIL-DTL-38999 SERIES I, III, IV	
 Southwest Microwave, Inc. 9055 South McKemy Street Tempe, Arizona 85284-2946 Telephone (480) 783-0201 Fax (480) 783-0360		DRN BY: D.HAKE	DATE: 2/12	MODEL NO.	51600-005S	REV. A
		SCALE 4:1		DWG. NO.	79BP61176	
SHEET: 1 OF 1						