

MODEL No.:

**55053-002J**

NOTE: Information herein is believed by Southwest Microwave, Inc. to be accurate. However, Southwest Microwave assumes no responsibility for any omissions or errors or inaccuracies for its use or for any infringements of patents or other rights of third parties that may result from its use. Data is intended for informational purpose only and does not constitute a contract of sale or any express or implied warranty, including any warranty of merchant ability or fitness for a particular purpose.

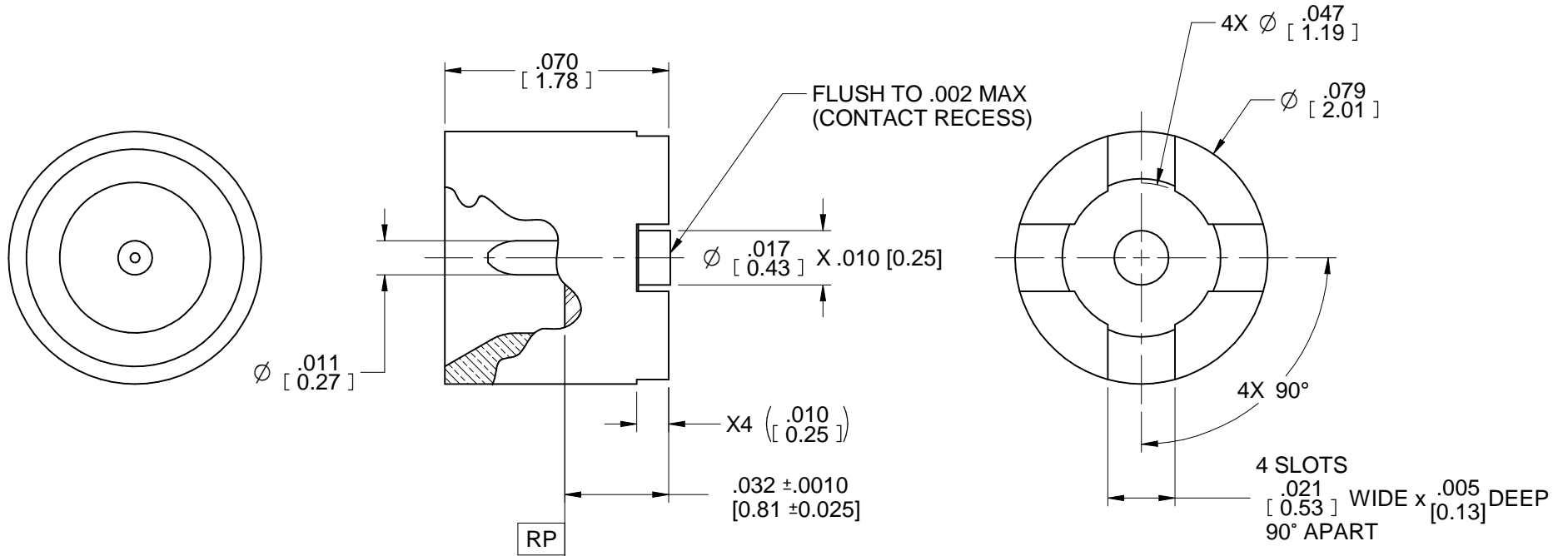

4. PCB GROUND AND CENTER CONTACT PAD SPECIFIC CONFIGURATIONS TO BE DETERMINED BY INDIVIDUAL APPLICATION REQUIREMENTS.

3. MATERIAL AND FINISH:

3.1 MATERIALS

HOUSING AND CENTER CONTACT:  
BeCu ALLOY

DIELECTRIC BEAD:  
PEEK HT

3.2 FINISHES

HOUSING AND CENTER CONTACT:  
GOLD PLATE PER MIL-DTL-45204  
- HOUSING: GOLD THICKNESS .000050 - .000100  
- CONTACT: GOLD THICKNESS .000025 - .000040

2. CONNECTOR DESIGN IS COMPATIBLE WITH CURRENT MATERIAL AND PROCESS REQUIREMENTS FOR RoHS AND WEEE PER EUROPEAN COMMUNITY DIRECTIVE 2002/95/EC.

1. ALL DIMENSIONS ARE IN INCHES. ALL ANGLES ARE IN DEGREES. DIMENSIONS SHOWN IN BRACKETS [XXX] ARE IN MILLIMETERS.

NOTES: UNLESS OTHERWISE SPECIFIED.

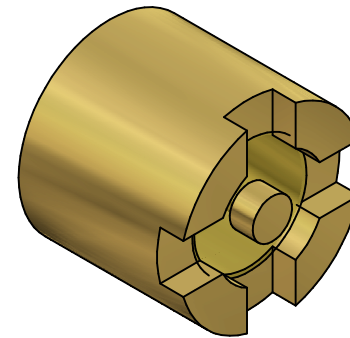
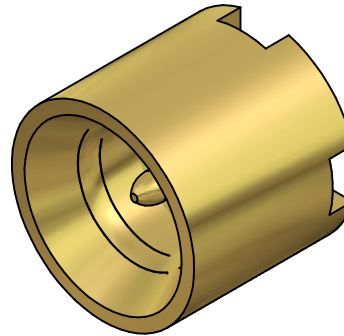

FSCM NO. **66049**

|         |           |         |               |                 |               |
|---------|-----------|---------|---------------|-----------------|---------------|
| REV. A1 | ECN: 9494 | BY: EJO | DATE: 4/26/16 | APRVD: B.CLYATT | DATE: 4/28/16 |
|---------|-----------|---------|---------------|-----------------|---------------|



Southwest Microwave, Inc.  
9055 South McKemy Street  
Tempe, Arizona 85284-2946  
Telephone (480) 783-0201  
Fax (480) 783-0360

TITLE  
Super-Mini Board-to-Board  
VERTICAL MOUNT JACK (FEMALE), (SMOOTH BORE)  
SURFACE MOUNT  
STRIPLINE LAUNCH

|               |                |                             |                |
|---------------|----------------|-----------------------------|----------------|
| DRN BY: EJO   | DATE: 12/11/15 | MODEL NO. <b>55053-002J</b> | REV. <b>A1</b> |
| SCALE 20:1    |                | DWG. NO. <b>79BB59402</b>   |                |
| SHEET: 1 OF 1 |                |                             |                |