

NOTE: Information herein is believed by Southwest Microwave, Inc. to be accurate. However, Southwest Microwave assumes no responsibility for any omissions or errors or inaccuracies for its use or for any infringements of patents or other rights of third parties that may result from its use. Data is intended for informational purpose only and does not constitute a contract of sale or any express or implied warranty, including any warranty of merchant ability or fitness for a particular purpose.

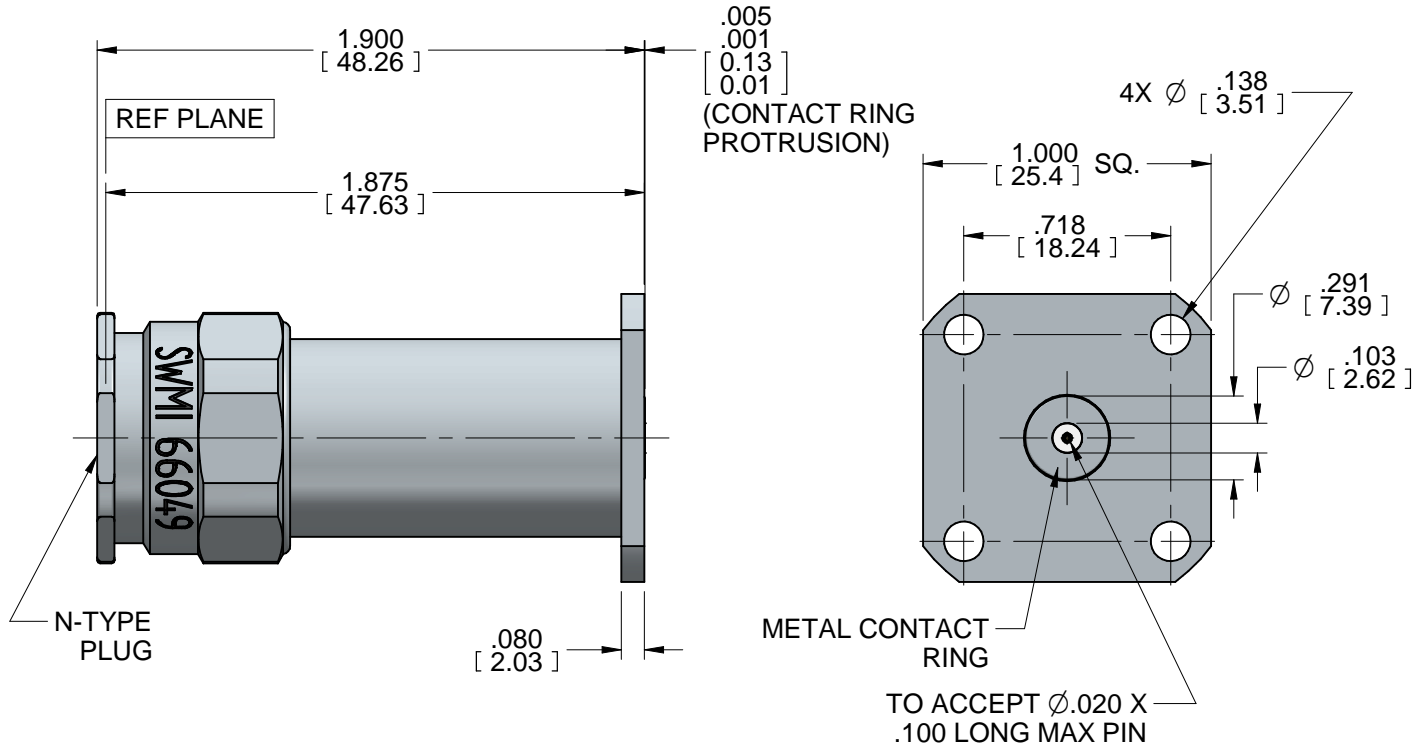

HOUSING:	STEEL, CRES ALLOY UNS-30300 PER ASTM A582
COUPLING NUT:	STEEL, CRES ALLOY UNS-30300 PER ASTM A582
RETAINING RING:	BeCu ALLOY UNS-C17200 PER ASTM B194
CONTACT:	BeCu ALLOY UNS-C17300 PER ASTM B196 GOLD PLATE PER MIL-DTL-45204
DIELECTRIC:	VIRGIN PTFE FLUOROCARBON PER ASTM D1710, TYPE 1, GRADE 1, CLASS B
DIELECTRIC BEAD:	KEL-F (PCTFE) PER ASTM D1430
CAPTURE BEAD:	ULTEM 1000 PER ASTM D5205
GASKET:	SILICON RUBBER ZZ-R-765 CLASS II B, GRADE 65-75
ITEM	MATERIAL & FINISH

2. INTERFACE I.A.W. MIL-STD-348

1. ALL DIMENSIONS ARE IN INCHES. ALL ANGLES ARE IN DEGREES. DIMENSIONS SHOWN IN BRACKETS [XXX] ARE IN MILLIMETERS.

NOTES: UNLESS OTHERWISE SPECIFIED.

REV A	RELEASED	DATE: 01/29/14	APRVD. PLC	DATE: 01/29/14	TITLE N-TYPE PLUG, 4 HOLE, 1.0SQ. FLANGE 1.9 LONG TO ACCEPT (.020) DIA. PIN			
 <p>Southwest Microwave, Inc. 9055 South McKemy Street Tempe, Arizona 85284-2946 Telephone (480) 783-0201 Fax (480) 783-0360</p>					DRN BY: DE	DATE: 1/29/14	MODEL NO. 311-11SF	REV. A
					SCALE: 3:1		DWG. NO. 79C61368	
					SHEET: 1 OF 1			