

Hermetic Seal Drill Information & Tools for Thread-in Connectors

Recommended Hole Pattern, Tools and Installation Fixtures for Optimum VSWR.

* To be determined by user for type and amount of solder preforms. Surface must be plated to provide a solderable surface.



Not for use with Kovar.

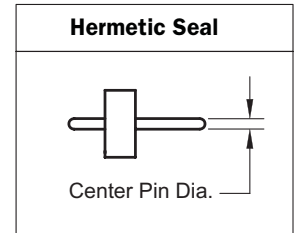
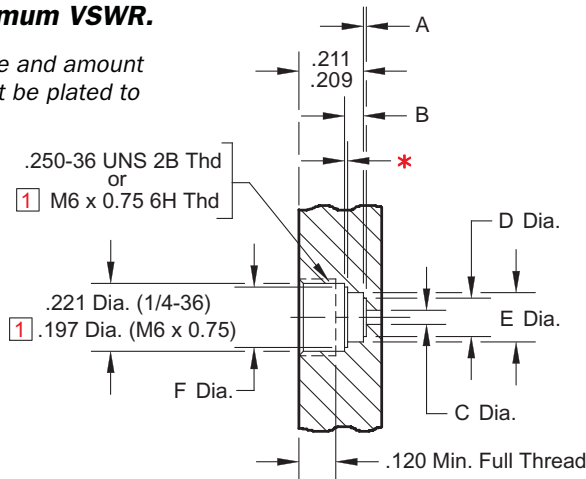

Refer to hermetic seal page.

Hermetic Seal No.	Center Pin Dia.	A	B	C	D	E	F	C'Bore Tool No.	Solder Tool No.
290-02G	.020	.010 .009	.062 .061	.0465 .0455	.126 .124	.161 .160	.178	T-292-4	T-220-2
290-01G	.018	.009 .007	.062 .061	.042 .041	.086 .084	.113 .112	.130	T-292-3	T-220-3
290-00G	.015	.007 .005	.0645 .0635	.035 .034	.080 .078	.102 .101	.120	T-292-2	T-220-1
290-06G 290-07G	.012	.0035 .0025	.057 .056	.028 .027	.067 .065	.079 .078	.098	T-292-5	T-220-5
1490-13G 1490-15G	.009	.006 .008	.057 .056	.0205 .0211	.0302 .0322	.072 .074	.091	T-1492-1 1 T-1492-2	T-1420-5 1 T-1420-6

1 For Connectors with Metric Thread (M6 x 0.75)

Seal Installation

1. Hold seal soldering tool upright.
2. Placing short end of seal center conductor into locating hole.
3. Place split solder ring preform over O.D. of seal. Let rest on tool.
4. Install into mounting hole keeping tool in upright position.
5. Solder seal into housing.
6. Remove tool and clean any residue as required.

Note:

Other soldering techniques may be utilized. Other methods should still achieve proper seal, center conductor centering, and position seal front surface orthogonal to connector axis to provide 360° of outer conductor contact for effective microwave performance.

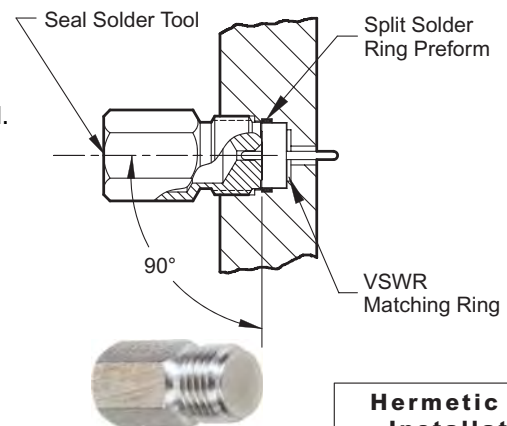

**Hermetic Seal
Installation**

(SSMA) Hermetic Seal Drill Information & Tools for SSMA Thread-in Connectors

Recommended Hole Pattern, Tools and Installation Fixtures for Optimum VSWR.

* To be determined by user for type and amount of solder preforms. Surface must be plated to provide a solderable surface.

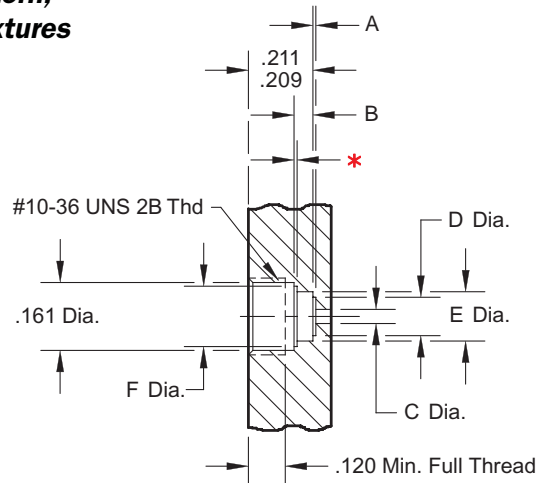

Not for use with Kovar.



Not for use with Kovar.

Hermetic Seal No.	Center Pin Dia.	A	B	C	D	E	F	C'Bore Tool No.	Solder Tool No.
290-01G	.018	.009 .007	.062 .061	.042 .041	.086 .084	.113 .112	.130	T-192-4	T-120-5
290-00G	.015	.007 .005	.0645 .0635	.035 .034	.080 .078	.102 .101	.120	T-192-3	T-120-4
290-06G 290-07G	.012	.0035 .0025	.057 .056	.028 .027	.067 .065	.079 .078	.098	T-192-1	T-120-2
1490-13G 1490-14G 1490-15G	.009	.006 .008	.057 .056	.0205 .0211	.0302 .0322	.072 .074	.091	T-192-2	T-120-3

Seal Installation

1. Hold seal soldering tool upright.
2. Placing short end of seal center conductor into locating hole.
3. Place split solder ring preform over O.D. of seal. Let rest on tool.
4. Install into mounting hole keeping tool in upright position.
5. Solder seal into housing.
6. Remove tool and clean any residue as required.

Note:

Other soldering techniques may be utilized. Other methods should still achieve proper seal, center conductor centering, and position seal front surface orthogonal to connector axis to provide 360° of outer conductor contact for effective microwave performance.

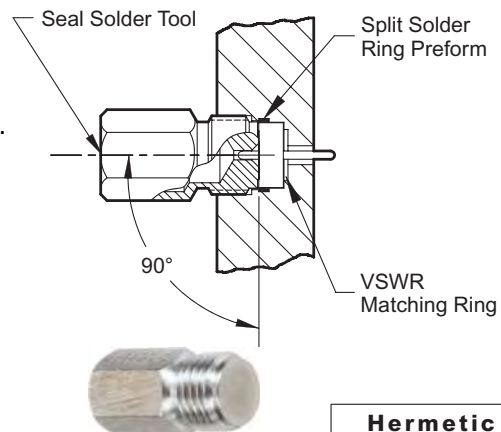

**Hermetic Seal
Installation**

0.9 mm (SSBT) Hermetic Seal Drill Information & Tools

Recommended Hole Pattern, Tools and Installation Fixtures for Optimum VSWR.

* To be determined by user for type and amount of solder preforms. Surface must be plated to provide a solderable surface.

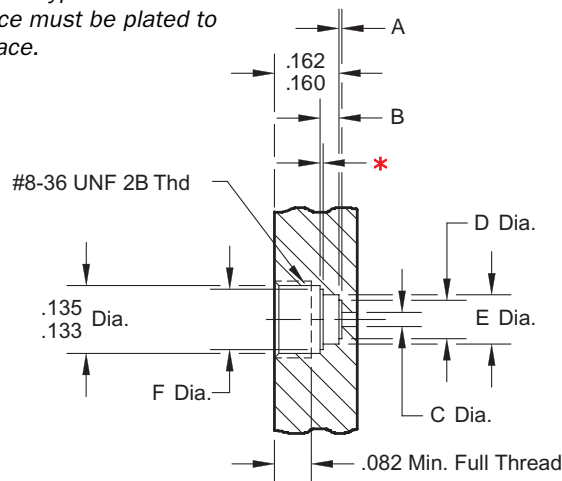

**Counter Bore Tool
(Tool No. Below)**

Not for use with Kovar.

Hermetic Seal No.	Center Pin Dia.	A	B	C	D	E	F	C'Bore Tool No.	Solder Tool No.
290-06G 290-07G	.012	.0035 .0025	.057 .056	.028 .027	.067 .065	.079 .078	.098	T-53022-2	T-53022-5
1490-13G 1490-14G 1490-15G	.009	.006 .008	.057 .056	.0205 .0211	.0302 .0322	.072 .074	.091	T-53022-4	T-53022-3

Seal Installation

1. Hold seal soldering tool upright.
2. Placing short end of seal center conductor into locating hole.
3. Place split solder ring preform over O.D. of seal. Let rest on tool.
4. Install into mounting hole keeping tool in upright position.
5. Solder seal into housing.
6. Remove tool and clean any residue as required.

Note:

Other soldering techniques may be utilized. Other methods should still achieve proper seal, center conductor centering, and position seal front surface orthogonal to connector axis to provide 360° of outer conductor contact for effective microwave performance.

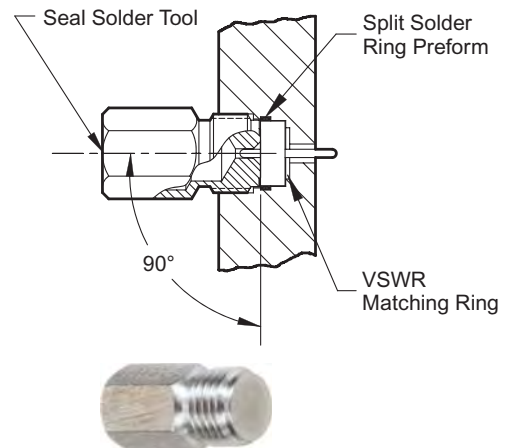

**Hermetic Seal
Installation**