

MODEL No.:

2421-04SF

NOTE: Information herein is believed by Southwest Microwave, Inc. to be accurate. However, Southwest Microwave assumes no responsibility for any omissions or errors or inaccuracies for its use or for any infringements of patents or other rights of third parties that may result from its use. Data is intended for informational purpose only and does not constitute a contract of sale or any express or implied warranty, including any warranty of merchant ability or fitness for a particular purpose.

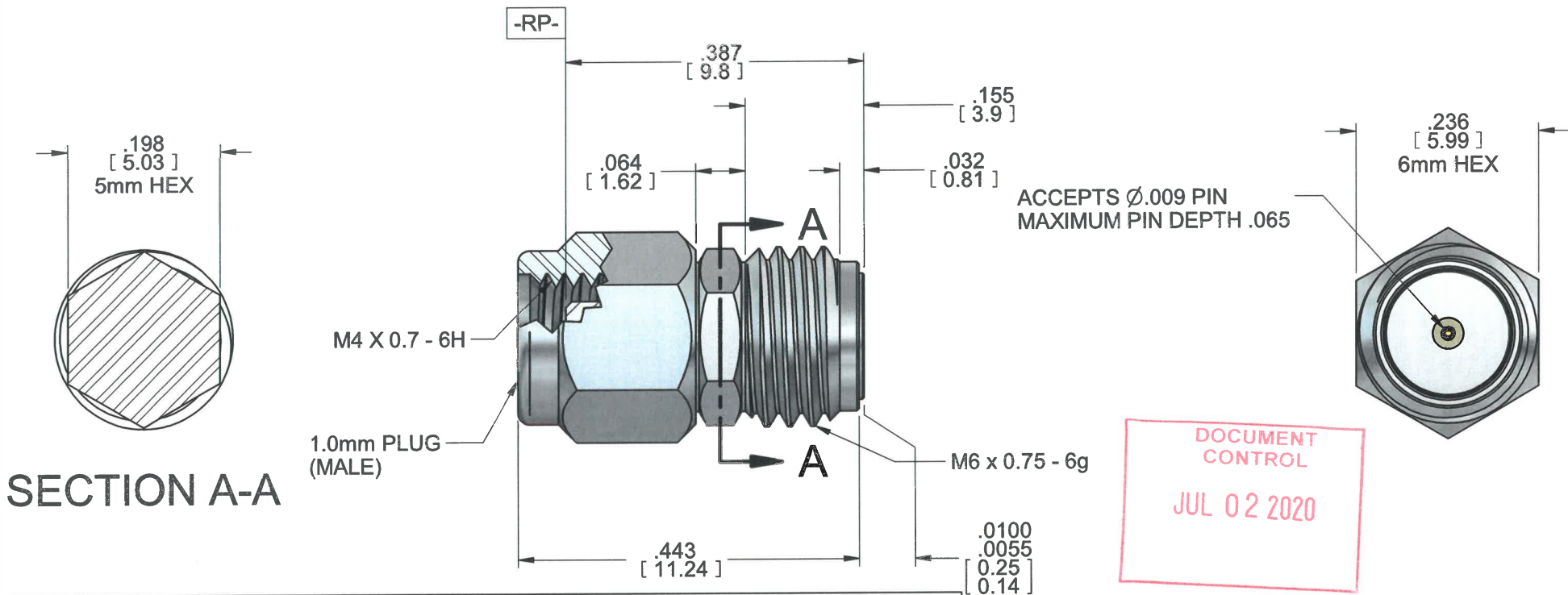

HOUSING:	STEEL, CRES ALLOY UNS-30300 PER ASTM A582 PASSIVATED PER ASTM A967-99
COUPLING NUT:	STEEL, CRES ALLOY UNS-30300 PER ASTM A582 PASSIVATED PER ASTM A967-99
RETAINING RING:	BeCu UNS-C17300 PER ASTM B196/197
CONTACT:	BeCu UNS-C17300 PER ASTM B196 GOLD PLATE PER MIL DTL-45204
CAPTURE BEAD:	ULTEM 1000 PER ASTM D5205
ITEM	MATERIAL & FINISH

DOCUMENT CONTROL  
JUL 02 2020

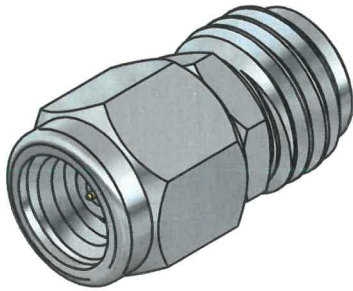

1. ALL DIMENSIONS ARE IN INCHES. ALL ANGLES ARE IN DEGREES. DIMENSIONS SHOWN IN BRACKETS [XXX] ARE IN MILLIMETERS.

NOTES: UNLESS OTHERWISE SPECIFIED.

REV B	ECN 475	REV BY JAC	APRVD. DE	DATE: 7/2/20
		Southwest Microwave, Inc. 9055 South McKemy Street Tempe, Arizona 85284-2946 Telephone (480) 783-0201 Fax (480) 783-0360		

TITLE			
MODEL 2421-04SF 1.0mm P mm Thdin (.009) M6			
DRN BY: JAC	DATE: 7/17/18	DWG. NO.	REV. B
SCALE: 5:1	79W68624		
SHEET: 1 OF 1			