

NOTE: Information herein is believed by Southwest Microwave, Inc. to be accurate. However, Southwest Microwave assumes no responsibility for any omissions or errors or inaccuracies for its use or for any infringements of patents or other rights of third parties that may result from its use. Data is intended for informational purpose only and does not constitute a contract of sale or any express or implied warranty, including any warranty of merchant ability or fitness for a particular purpose.

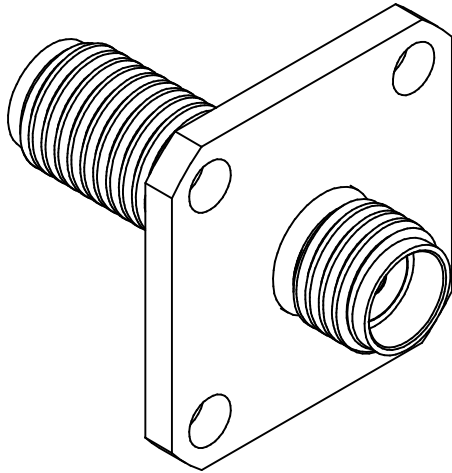
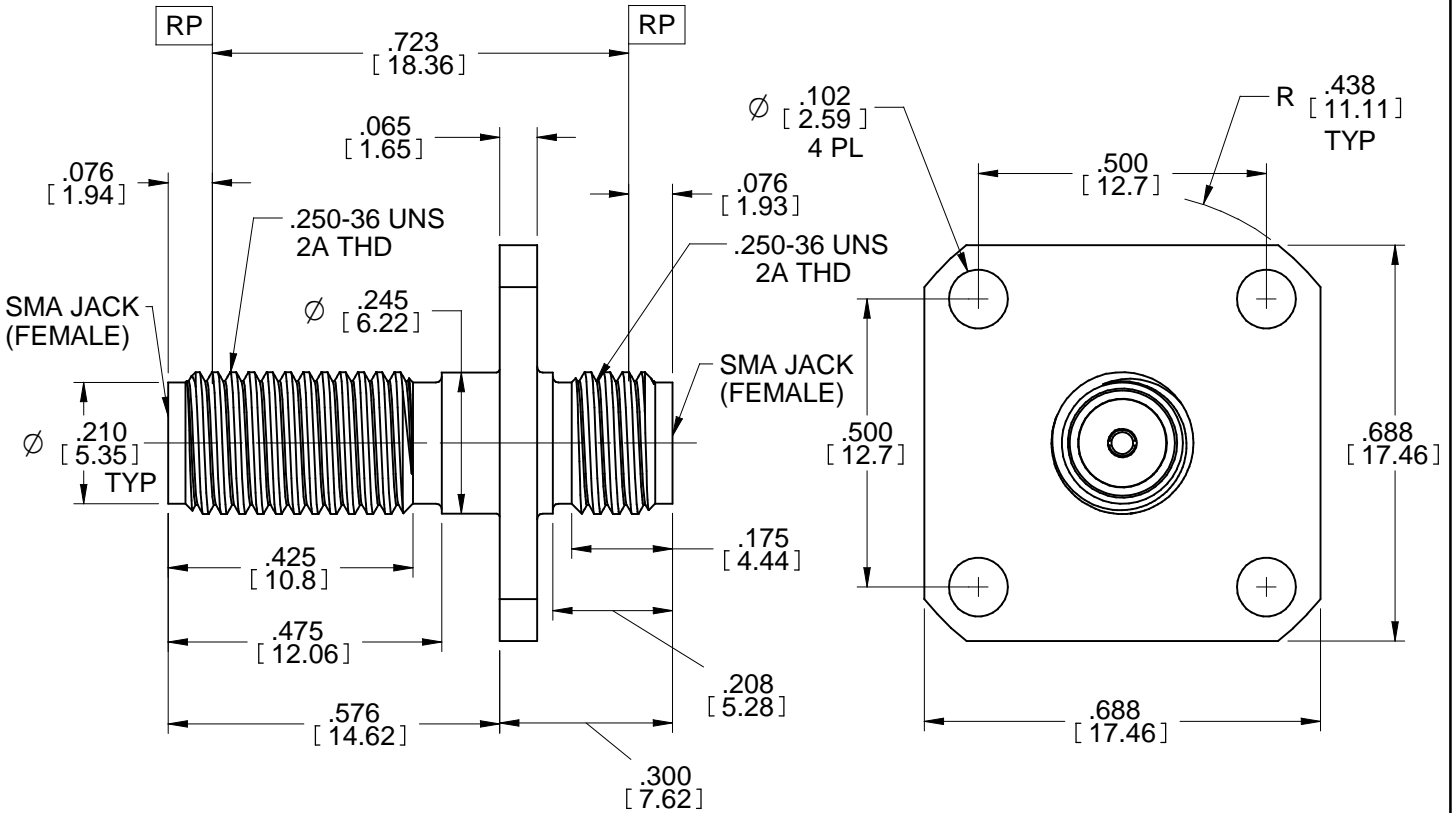

HOUSING:	STEEL, CRES ALLOY UNS-S30300 PER ASTM A582 PASSIVATE PER ASTM A967
CONTACT:	BeCu UNS-C17300 PER ASTM B196 GOLD PLATE PER MIL-DTL-45204
DIELECTRIC:	VIRGIN TFE FLUOROCARBON PER ASTM D1710 AND ASTM D1457
DIELECTRIC BEAD:	ULTEM PER ASTM D5205
ITEM	MATERIAL & FINISH

2. INTERFACE I.A.W. MIL-STD-348

1. ALL DIMENSIONS ARE IN INCHES. ALL ANGLES ARE IN DEGREES. DIMENSIONS SHOWN IN BRACKETS [XXX] ARE IN MILLIMETERS.

NOTES: UNLESS OTHERWISE SPECIFIED.

SPECIFICATIONS	91B60183
INTERFACE	91B56188
SPECIFICATION GROUP	DRAWING NO.

REV A	RELEASE	DATE: 9/13/10	APRVD. BR	DATE: 9/22/10	TITLE SMA JACK (F) TO SMA JACK (F) PANEL MOUNT FEEDTHRU, 11/16" SQUARE FLANGE			
 <p>Southwest Microwave, Inc. 9055 South McKemy Street Tempe, Arizona 85284-2946 Telephone (480) 783-0201 Fax (480) 783-0360</p>					DRN BY: erico	DATE: 9/13/2010	MODEL NO. 232-514SF	REV. A
					SCALE: 3:1	DWG. NO. 79B60429		
					SHEET: 1 OF 1			

# Southwest Microwave, Inc.

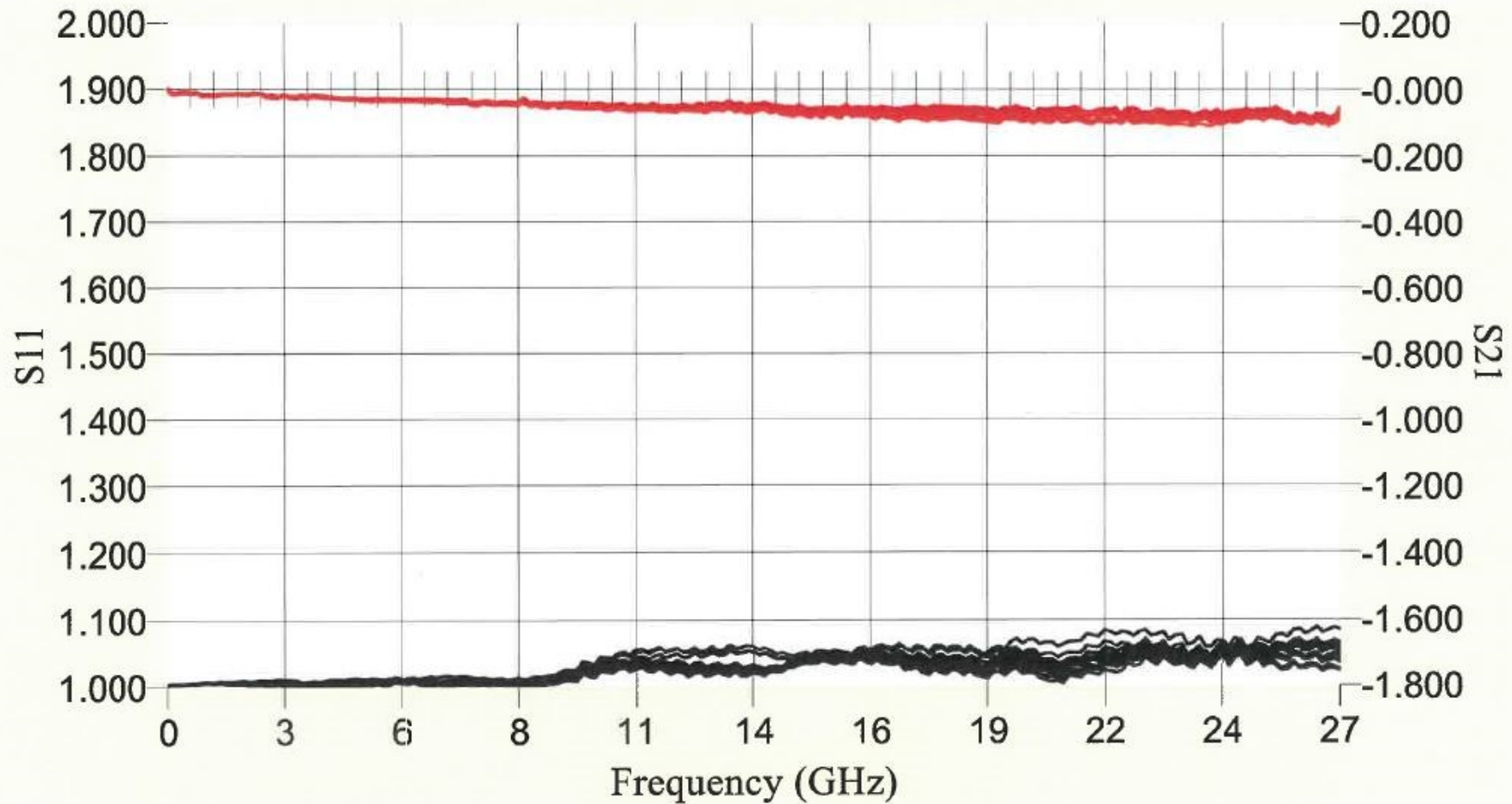

Operator Ann Date 10-22-2019 @ 08:26:47 Model number: 232-502SF QCIR:110304-000; Serial number 9

File name 9.dat Measurements,1,2,3,4,5,6,7,8,9,10,11,12,13,14,15,16

Notes SMA J TO SMA J ADP SOLT