

NOTE: Information herein is believed by Southwest Microwave, Inc. to be accurate. However, Southwest Microwave assumes no responsibility for any omissions or errors or inaccuracies for its use or for any infringements of patents or other rights of third parties that may result from its use. Data is intended for informational purpose only and does not constitute a contract of sale or any express or implied warranty, including any warranty of merchant ability or fitness for a particular purpose.

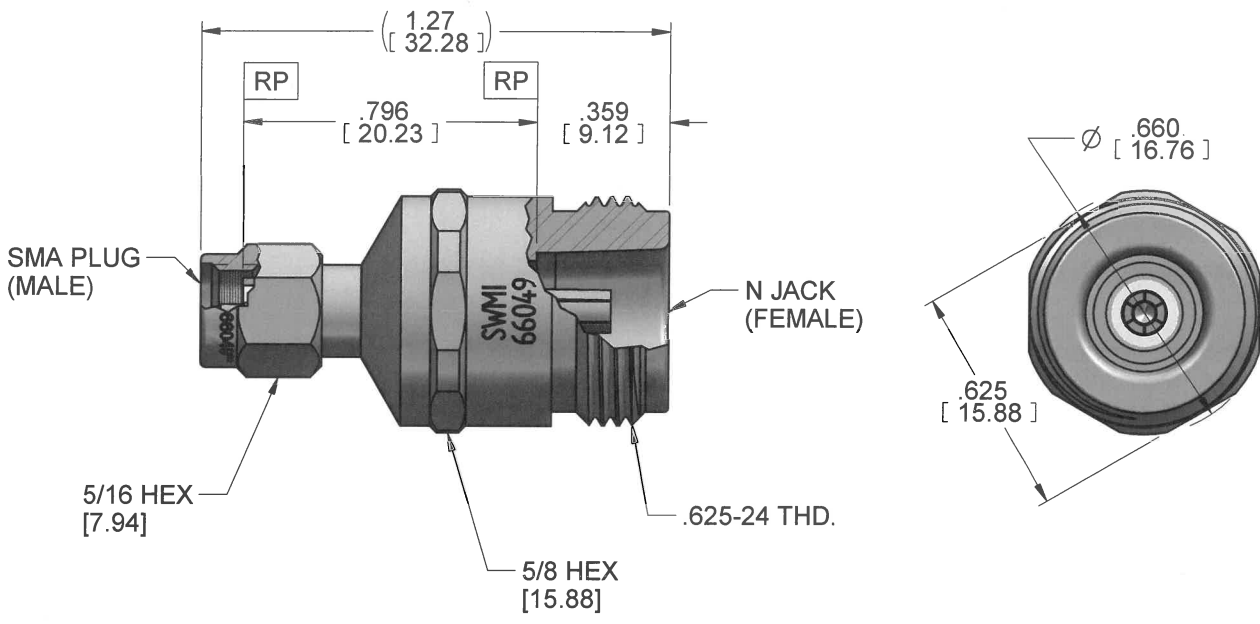

HOUSING:	STEEL, CRES ALLOY UNS-30300 PER ASTM A582
COUPLING NUT:	STEEL, CRES ALLOY UNS-30300 PER ASTM A582
RETAINING RING:	BeCu ALLOY UNS-C17300 COND. TD02 TO TD04 PER ASTM B196
CONTACT:	BeCu ALLOY UNS-C17300 COND. TH02 TO TH04 PER ASTM B196 GOLD PLATE PER MIL-DTL-45204
DIELECTRIC:	VIRGIN PTFE FLUOROCARBON PER ASTM D1710 TYPE 1, GRADE 1, CLASS B
BEAD RING:	ULTEM 1000 PER ASTM D5205
GASKET:	SILICON RUBBER ZZ-R-765 CLASS II B, GRADE 65-75
ITEM	MATERIAL & FINISH

- 2. INTERFACE I.A.W. THE REQUIREMENTS OF MIL-STD-348 FIG.s 304-2 AND 310-2.
- 1. ALL DIMENSIONS ARE IN INCHES. ALL ANGLES ARE IN DEGREES. DIMENSIONS SHOWN IN BRACKETS [XXX] ARE IN MILLIMETERS.

NOTES: UNLESS OTHERWISE SPECIFIED.

CONTACT GAGING SPEC	91C54030
N SOCKET:	
SPECIFICATION:	91Y58687
SPECIFICATION GROUP	DRAWING NO.

REV B	ECN: 8963	DATE: 05/19/11	APRVD. <i>BR</i>	DATE: 9/26/11	TITLE SMA PLUG TO N JACK ADAPTER												
 <p>Southwest Microwave, Inc. 9055 South McKerny Street Tempe, Arizona 85284-2946 Telephone (480) 783-0201 Fax (480) 783-0360</p>					<table border="1"> <tr> <td>DRN BY: EJO</td> <td>DATE: 06/05</td> <td>MODEL NO. 2330SF</td> <td>REV. B</td> </tr> <tr> <td colspan="2">SCALE: 2:1</td> <td>DWG. NO. 79Y58874</td> <td></td> </tr> <tr> <td colspan="2">SHEET: 1 OF 1</td> <td></td> <td></td> </tr> </table>	DRN BY: EJO	DATE: 06/05	MODEL NO. 2330SF	REV. B	SCALE: 2:1		DWG. NO. 79Y58874		SHEET: 1 OF 1			
DRN BY: EJO	DATE: 06/05	MODEL NO. 2330SF	REV. B														
SCALE: 2:1		DWG. NO. 79Y58874															
SHEET: 1 OF 1																	

MPD-A-0-L_3x

Southwest Microwave, Inc.

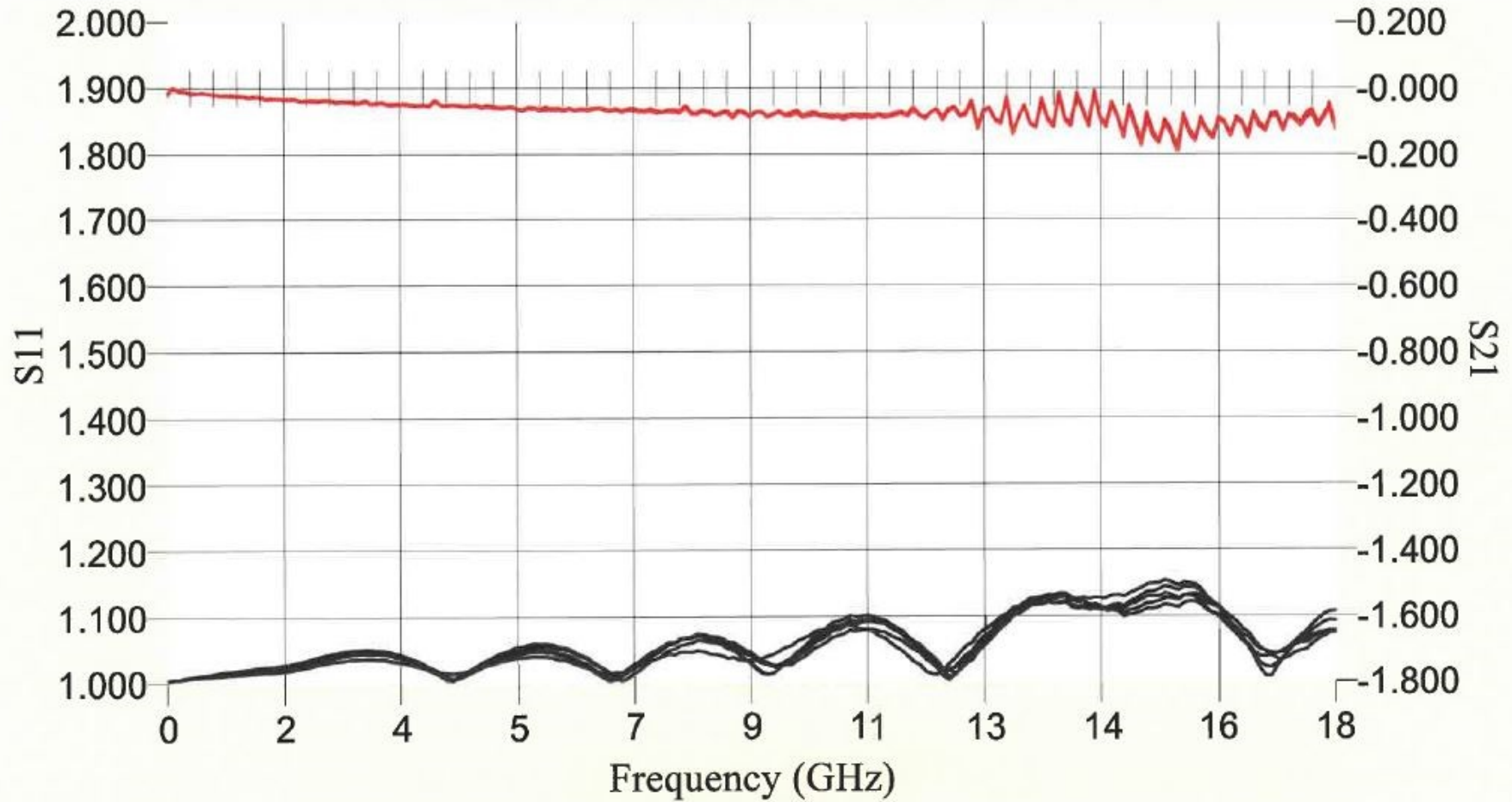

Operator Ann Date 03-06-2020 @ 10:01:15 Model number: 2310SF QCIR:118613-000; Serial number 5

File name 5.dat Measurements,1,2,3,4,5

Notes SMA J TO N J ADP SOLT