

MODEL No.:

55057-010J

NOTE: Information herein is believed by Southwest Microwave, Inc. to be accurate. However, Southwest Microwave assumes no responsibility for any omissions or errors or inaccuracies for its use or for any infringements of patents or other rights of third parties that may result from its use. Data is intended for informational purpose only and does not constitute a contract of sale or any express or implied warranty, including any warranty of merchant ability or fitness for a particular purpose.

DOCUMENT CONTROL  
SEP 18 2020

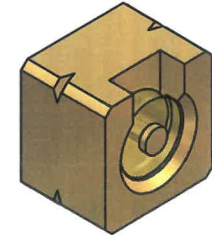
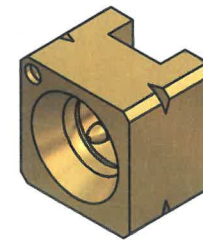
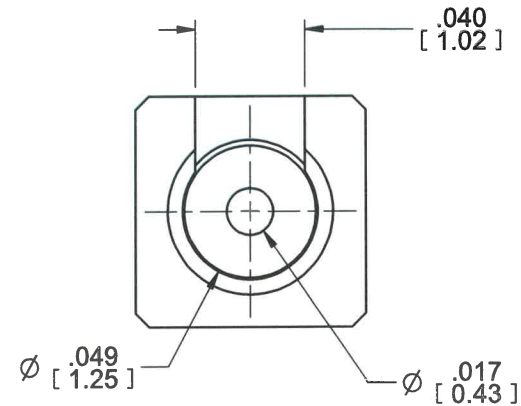
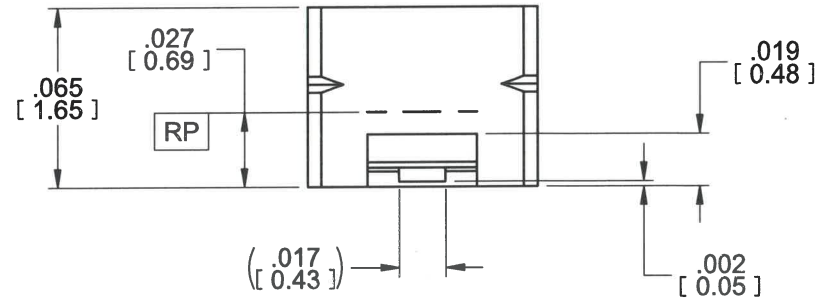
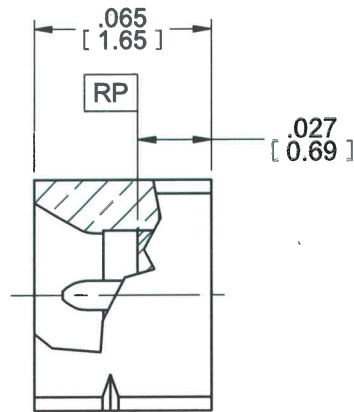
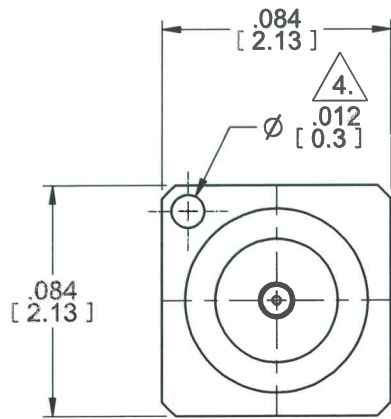

HOUSING:	BeCu UNS-C17300 PER ASTM B196/197
CONTACT:	GOLD PLATE PER MIL-DTL-45204
DIELECTRIC:	PEEK VICTREX HT POLYMER G22
ITEM	MATERIAL & FINISH

4. INDICATOR FOR TRACE CAVITY.
3. PCB GROUND AND CENTER CONTACT PAD SPECIFIC CONFIGURATIONS TO BE DETERMINED BY INDIVIDUAL APPLICATION REQUIREMENTS.
2. CONNECTOR DESIGN IS COMPATIBLE WITH CURRENT MATERIAL AND PROCESS REQUIREMENTS FOR RoHS AND WEEE PER EUROPEAN COMMUNITY DIRECTIVE 2002/95/EC.
1. ALL DIMENSIONS ARE IN INCHES. ALL ANGLES ARE IN DEGREES. DIMENSIONS SHOWN IN BRACKETS [xxx] ARE IN MILLIMETERS.
- NOTES: UNLESS OTHERWISE SPECIFIED.

REV A PRODUCTION RELEASE APRVD. DE DATE: 9/18/20



Southwest Microwave, Inc.  
9055 South McKemy Street  
Tempe, Arizona 85284-2946  
Telephone (480) 783-0201  
Fax (480) 783-0360

TITLE  
**SSBB20 JACK SURFACE MOUNT  
.084 DETENT MICROSTRIP**

DRN BY: JAC  
DATE: 09/03/20  
SCALE: 15:1  
SHEET: 1 OF 1

DWG. NO.  
**79BB68598**

REV.  
**A**