

Hermetic Seal Transition for Flange Mount Connectors

Recommended Hole Pattern, Tools and Installation Fixtures for Optimum VSWR.

* To be determined by user for type and amount of solder preforms. Surface must be plated to provide a solderable surface.

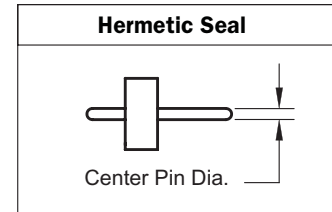

Refer to hermetic seal page.

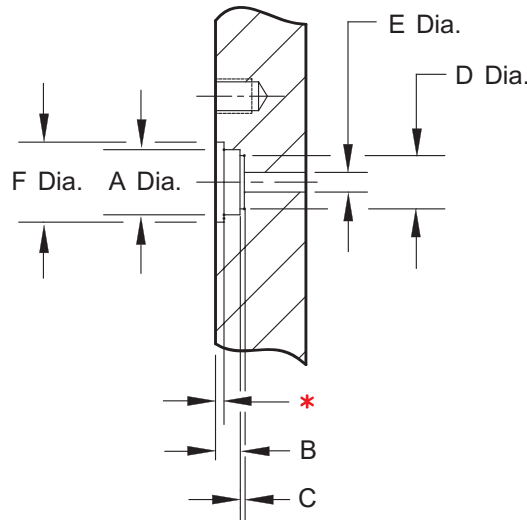

Counter Bore Tool
Not for use with Kovar.

Hermetic Seal No.	Center Pin Dia.	A	B	C	D	E	F	C'Bore Tool No.
490-00G	.036	$\frac{.272}{.274}$	$\frac{.061}{.062}$	$\frac{.018}{.022}$	$\frac{.148}{.152}$	$\frac{.0823}{.0822}$.288	
290-02G	.020	$\frac{.161}{.160}$	$\frac{.062}{.061}$	$\frac{.010}{.009}$	$\frac{.126}{.124}$	$\frac{.0465}{.0455}$.178	T-291-4
290-01G	.018	$\frac{.113}{.112}$	$\frac{.062}{.061}$	$\frac{.009}{.007}$	$\frac{.086}{.084}$	$\frac{.042}{.041}$.130	T-291-3
290-00G	.015	$\frac{.102}{.101}$	$\frac{.0645}{.0635}$	$\frac{.007}{.005}$	$\frac{.080}{.078}$	$\frac{.035}{.034}$.120	T-291-2
290-06G 290-07G	.012	$\frac{.079}{.078}$	$\frac{.057}{.056}$	$\frac{.0035}{.0025}$	$\frac{.067}{.065}$	$\frac{.028}{.027}$.098	T-291-5 ** T-53029-2
1490-13G 1490-14G 1490-15G	.009	$\frac{.072}{.074}$	$\frac{.057}{.058}$	$\frac{.006}{.008}$	$\frac{.0302}{.0322}$	$\frac{.0205}{.0211}$.091	T-1491-1 ** T-53029-4

** 0.9 mm (SSBT)

**Hermetic Seal
Installation**

Connector Mounting Hole Chart for Flange Mount Connectors

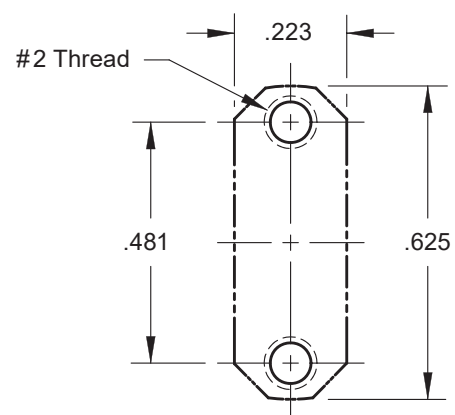
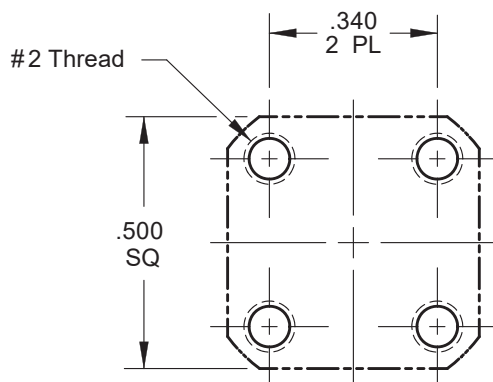
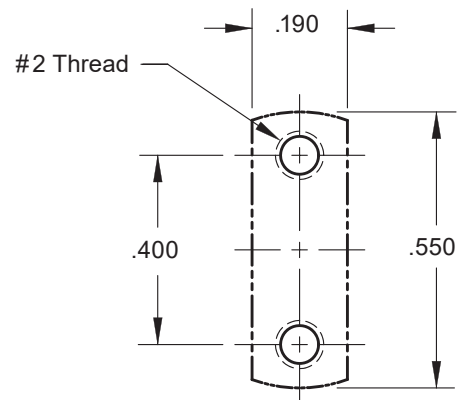
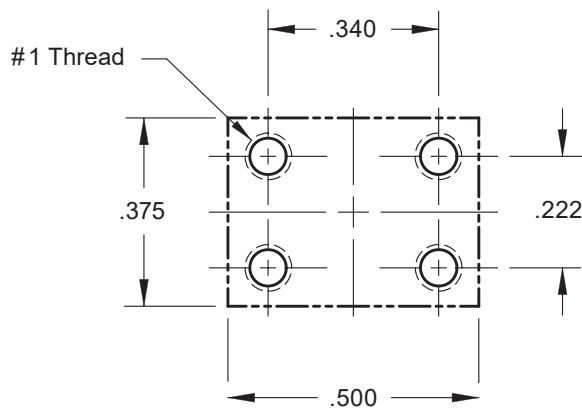
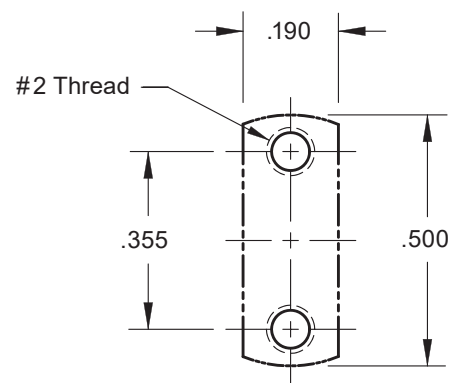
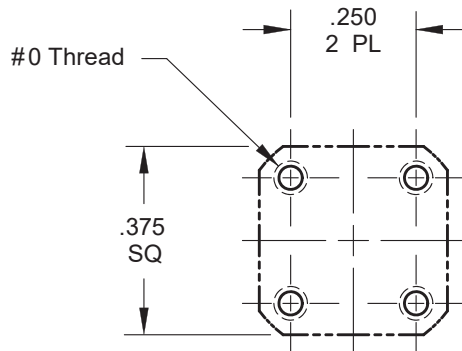

Southwest Microwave suggests the use of fillister head screws for mounting connectors.

**Detail Mounting Hole Chart
for Flange Mount Connectors**

Connector Mounting Hole Chart for Flange Mount Connectors

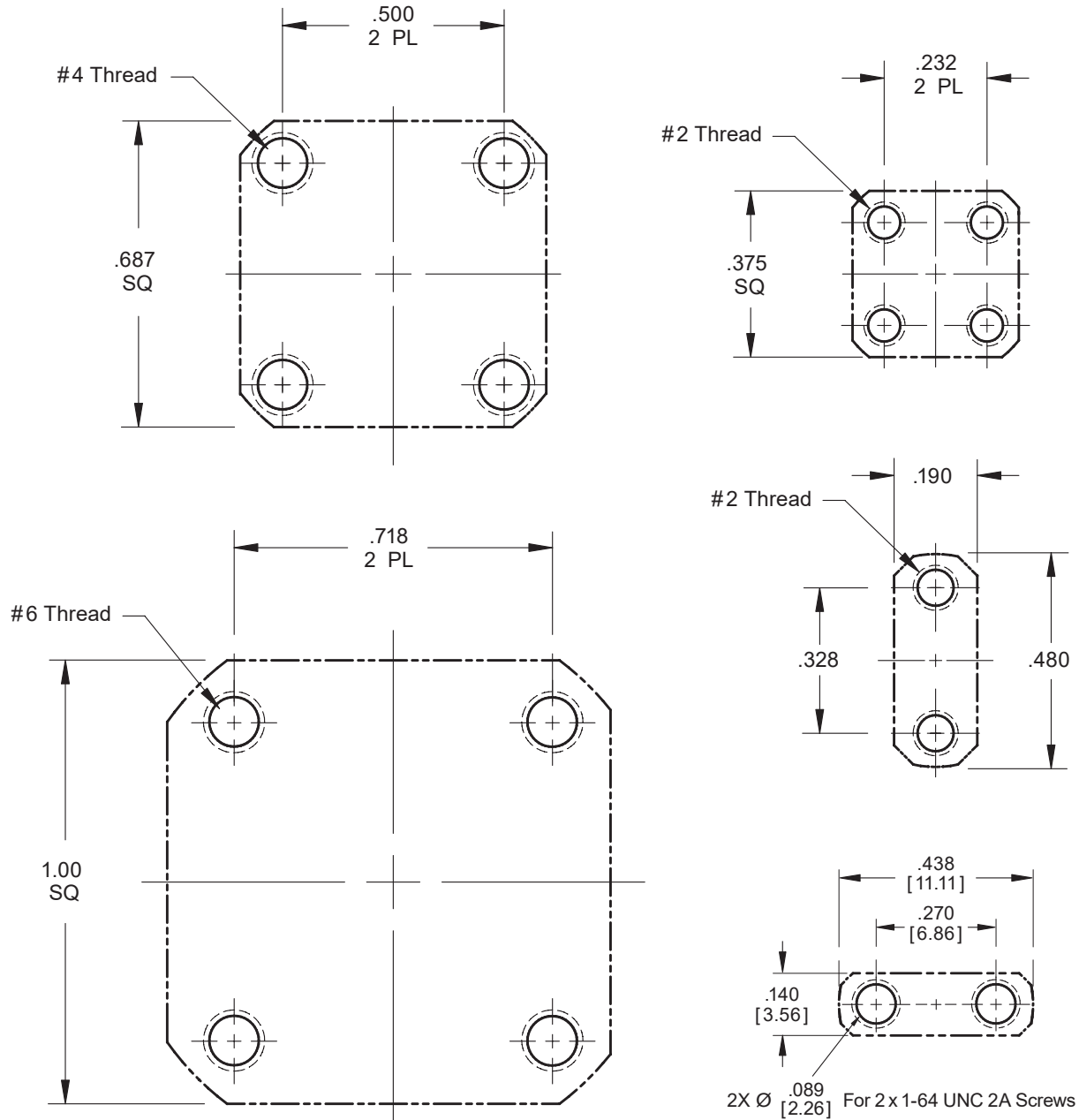

Southwest Microwave suggests the use of fillister head screws for mounting connectors.

**Detail Mounting Hole Chart
for Flange Mount Connectors**