

MODEL No.:

55053-008J

NOTE: Information herein is believed by Southwest Microwave, Inc. to be accurate. However, Southwest Microwave assumes no responsibility for any omissions or errors or inaccuracies for its use or for any infringements of patents or other rights of third parties that may result from its use. Data is intended for informational purpose only and does not constitute a contract of sale or any express or implied warranty, including any warranty of merchant ability or fitness for a particular purpose.

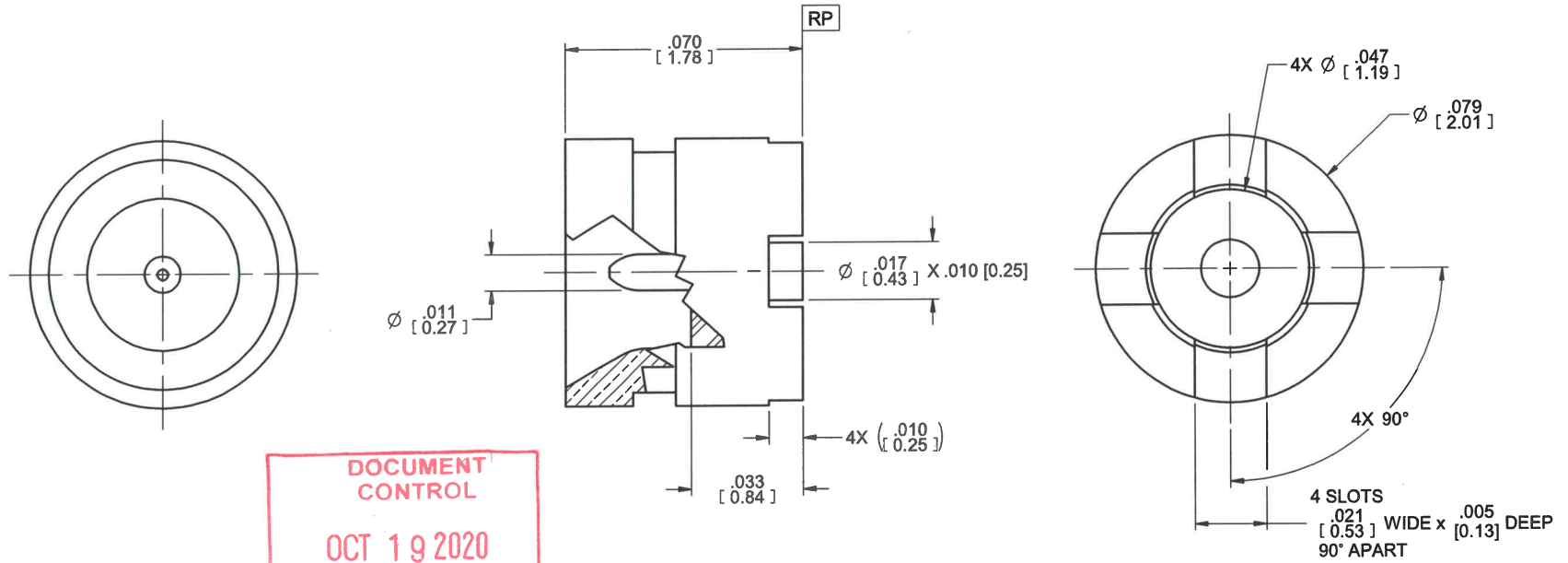

HOUSING:	BeCu UNS-C17300 PER ASTM B196/197
CONTACT:	GOLD PLATE PER MIL-DTL-45204
DIELECTRIC:	PEEK VICTREX HT POLYMER G22
ITEM	MATERIAL & FINISH

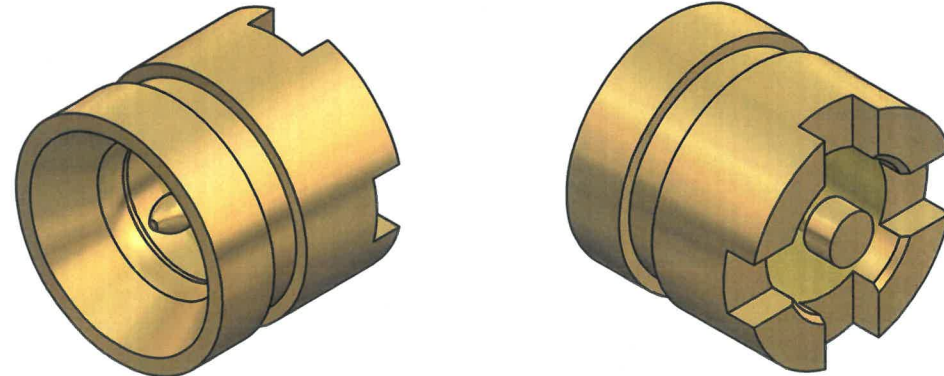

- PCB GROUND AND CENTER CONTACT PAD SPECIFIC CONFIGURATIONS TO BE DETERMINED BY INDIVIDUAL APPLICATION REQUIREMENTS.
 - CONNECTOR DESIGN IS COMPATIBLE WITH CURRENT MATERIAL AND PROCESS REQUIREMENTS FOR RoHS AND WEEE PER EUROPEAN COMMUNITY DIRECTIVE 2002/95/EC.
 - ALL DIMENSIONS ARE IN INCHES. ALL ANGLES ARE IN DEGREES. DIMENSIONS SHOWN IN BRACKETS [XXX] ARE IN MILLIMETERS.
- NOTES: UNLESS OTHERWISE SPECIFIED.

REV B	ECN 546	REV BY JAC	APRVD 10/16/20	DATE DE	TITLE	DRN BY: JAC	DATE: 03/20/20	DWG. NO.	REV. B
 Southwest Microwave, Inc. 9055 South McKerny Street Tempe, Arizona 85284-2946 Telephone (480) 783-0201 Fax (480) 783-0360					SSBB20 JACK SURFACE MOUNT Ø.070 DETENT STRIPLINE		79Y69139	B	
					SCALE: 20:1	SHEET: 1 OF 1			