

NOTE: Information herein is believed by Southwest Microwave, Inc. to be accurate. However, Southwest Microwave assumes no responsibility for any omissions or errors or inaccuracies for its use or for any infringements of patents or other rights of third parties that may result from its use. Data is intended for informational purpose only and does not constitute a contract of sale or any express or implied warranty, including any warranty of merchant ability or fitness for a particular purpose.

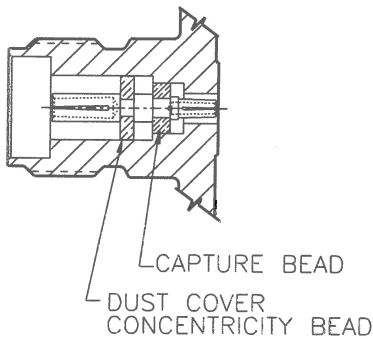
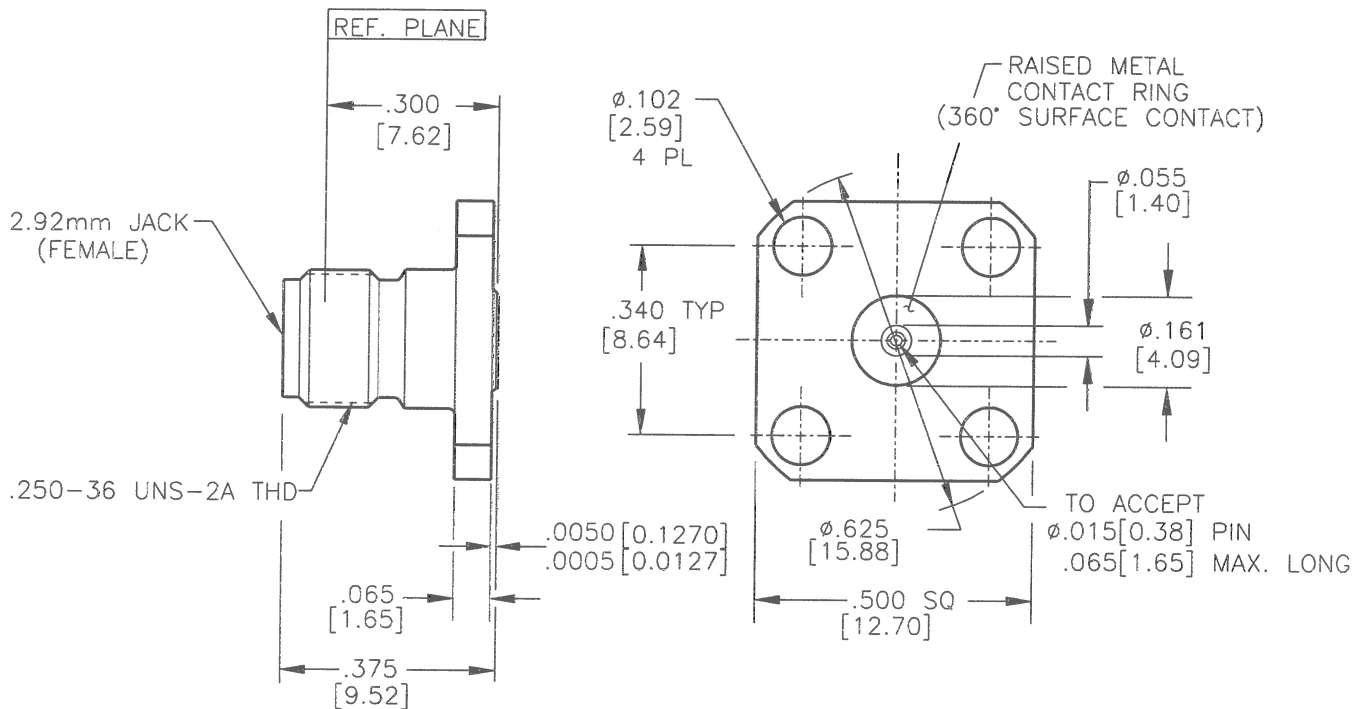

HOUSING:	STEEL, CRES ALLOY UNS-S30300 PER ASTM-A582. PASSIVATE PER ASTM-A967-99
CONTACT:	BeCu UNS-C17300 PER ASTM-B-196/197 GOLD PLATE PER MIL-G-45204
BEAD RING:	1) KEL-F PER MIL-P-46036 2) ULTEM 1000 PER ASTM-D-5205
ITEM	MATERIAL & FINISH

2. INTERFACE I.A.W. MIL-STD-348

1. ALL DIMENSIONS ARE IN INCHES, ALL ANGLES ARE IN DEGREES. DIMENSIONS SHOWN IN BRACKETS [XXX] ARE MILLIMETERS.

TOLERANCES ARE BASED UPON DIMENSIONS IN INCHES. METRIC DIMENSIONS ARE FOR "REFERENCE ONLY".

CONTACT GAGING SPEC.	91K59162
SPECIFICATIONS	91K59161
INTERFACE	91K52019
SPECIFICATION GROUP	DRAWING NO.

NOTES: UNLESS OTHERWISE SPECIFIED

REV A	RELEASE	DATE: 8/18/06	APRVD. EDO	DATE: 12/14/06	TITLE
					2.92mm JACK 4 HOLE .500 SQ FLANGE TO ACCEPT (.015) DIA. PIN
 Southwest Microwave, Inc. 9055 South McKemy Street Tempe, Arizona 85284-2946 Telephone (480) 783-0201 Fax (480) 783-0360					DRN BY: SS DATE: 8/06 SCALE: 3:1 SHEET: 1 OF 1
				MODEL NO.	1012-08SF
				DWG. NO.	79K58674
					REV. A

O.L.-A-303 REV0