

MODEL No.:

22270-01G

NOTE: Information herein is believed by Southwest Microwave, Inc. to be accurate. However, Southwest Microwave assumes no responsibility for any omissions or errors or inaccuracies for its use or for any infringements of patents or other rights of third parties that may result from its use. Data is intended for informational purpose only and does not constitute a contract of sale or any express or implied warranty, including any warranty of merchant ability or fitness for a particular purpose.

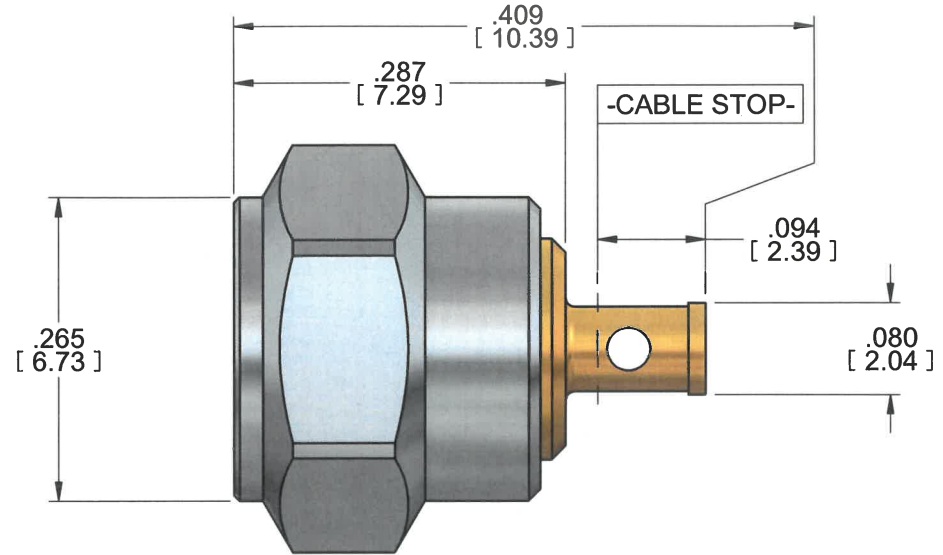
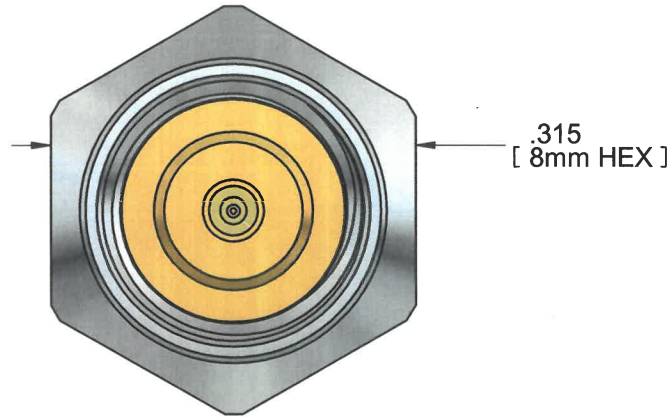

HOUSING: BUSHING:	BeCu ALLOY UNS-C17300, TEMPER TD04 PER ASTM B196/197 GOLD PLATE PER MIL-DTL-45204, TYPE II, GRADE C, NICKEL HARDENED OVER ELECTROLESS NICKEL PER MIL-C-26074.
CONTACT:	BeCu ALLOY UNS-C17300, TEMPER TD04 PER ASTM B196/197 GOLD PLATE PER ASTM B488, TYPE II, CODE C, CLASS 1.27 OVER ELECTRO-PLATED NICKEL PER SAE AMS-QQ-N-290 CLASS 1
CAPTURE BEAD:	ULTEM 1000 PER ASTM D5205
RETAINING RING:	HARDENED BeCu ALLOY, 1/2H PER ASTM B194/197
COUPLING NUT:	STAINLESS STEEL ALLOY UNS S30300 PER ASTM A582 PASSIVATED PER ASTM A967
ITEM	MATERIAL & FINISH

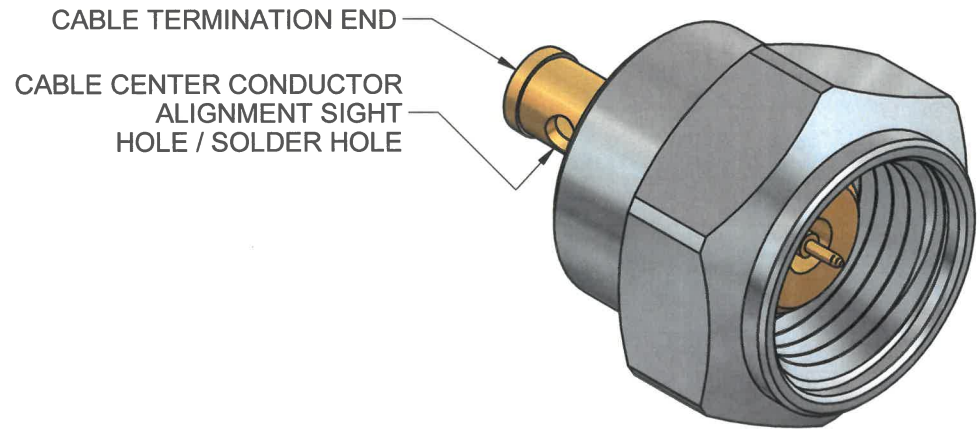

2. PERFORMANCE IS DEPENDENT UPON THE SPECIFIC CABLE SELECTION AND THIRD-PARTY CABLE PREPARATION BEYOND THE CONTROL OF SOUTHWEST MICROWAVE.

1. ALL DIMENSIONS ARE IN INCHES. ALL ANGLES ARE IN DEGREES. DIMENSIONS SHOWN IN BRACKETS [XXX] ARE IN MILLIMETERS.

NOTES: UNLESS OTHERWISE SPECIFIED.

REV: A	RELEASE	APRVD: <i>DE</i>	DATE: 11/1/2023	TITLE 1.35mm PLUG DIRECT SOLDER .047 SOLID CORE CABLE	
 Southwest Microwave, Inc. 9055 South McKerny Street Tempe, Arizona 85284-2946 Telephone (480) 783-0201 Fax (480) 783-0360		DRN BY: JAC	DATE: 10/18/23	MODEL NO.	22270-01G
		SHEET: 1 OF 1		DWG. NO.	79E70286
				REV.	A