

NOTE: Information herein is believed by Southwest Microwave, Inc. to be accurate. However, Southwest Microwave assumes no responsibility for any omissions or errors or inaccuracies for its use or for any infringements of patents or other rights of third parties that may result from its use. Data is intended for informational purpose only and does not constitute a contract of sale or any express or implied warranty, including any warranty of merchant ability or fitness for a particular purpose.

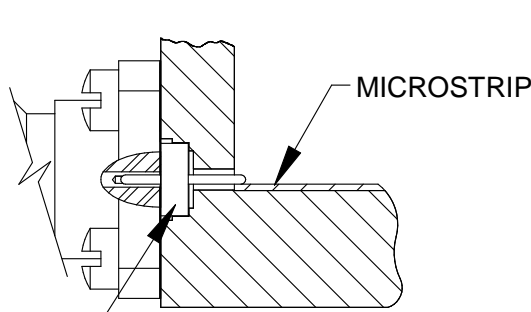

#91B52152
APPLICATION DOCUMENT

FLANGE MOUNT APPLICATION

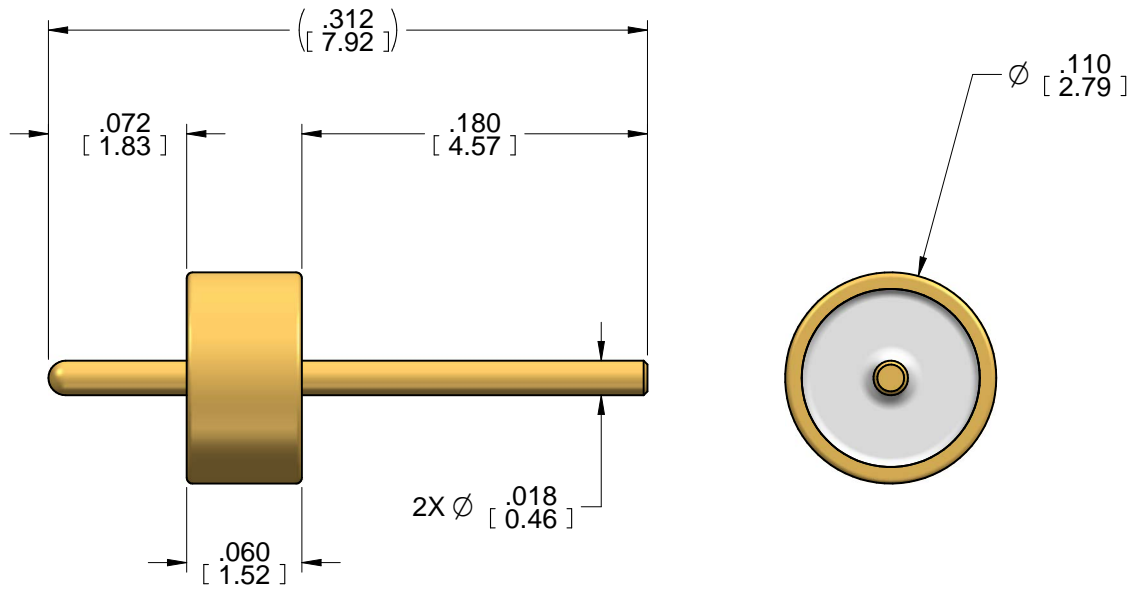
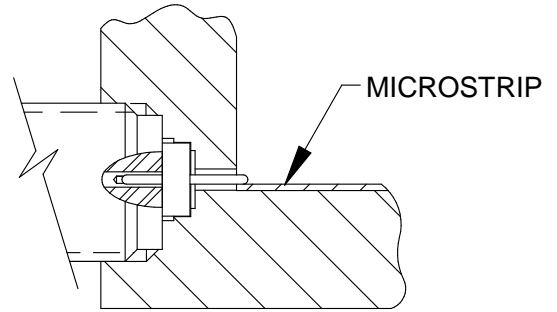

#91B52156
APPLICATION DOCUMENT

THREAD IN APPLICATION

4. GLASS: 7070 OR EQUIVALENT.
3. METAL PARTS: KOVAR
GOLD PLATED .000050" MIN PER MIL-G-45204
2. IMPEDANCE: 50 OHMS NOMINAL.
1. ALL DIMENSIONS ARE IN INCHES. ALL ANGLES ARE IN DEGREES. DIMENSIONS SHOWN IN BRACKETS [XXX] ARE IN MILLIMETERS.

NOTES: UNLESS OTHERWISE SPECIFIED.

APPLICATION REFERENCE
N.T.S.

**DOCUMENT
CONTROL
JUN 21 2024**

REV B	ECN 996	ECN BY: JAC	APRVD. DE	DATE: 06/21/24	TITLE 50 OHM GLASS SEAL (.018) .110D .312L			
 <p>Southwest Microwave, Inc. 9055 South McKemy Street Tempe, Arizona 85284-2946 Telephone (480) 783-0201 Fax (480) 783-0360</p>					DRN BY: RC	DATE: 04/91	MODEL NO.	REV. B
					SCALE: 10:1		290-01G	
					SHEET: 1 OF 1		DWG. NO. 79B50318	