

MODEL No.:

54070-001B

NOTE: Information herein is believed by Southwest Microwave, Inc. to be accurate. However, Southwest Microwave assumes no responsibility for any omissions or errors or inaccuracies for its use or for any infringements of patents or other rights of third parties that may result from its use. Data is intended for informational purpose only and does not constitute a contract of sale or any express or implied warranty, including any warranty of merchant ability or fitness for a particular purpose.

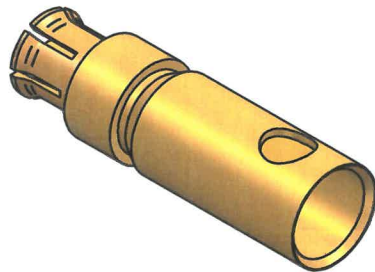
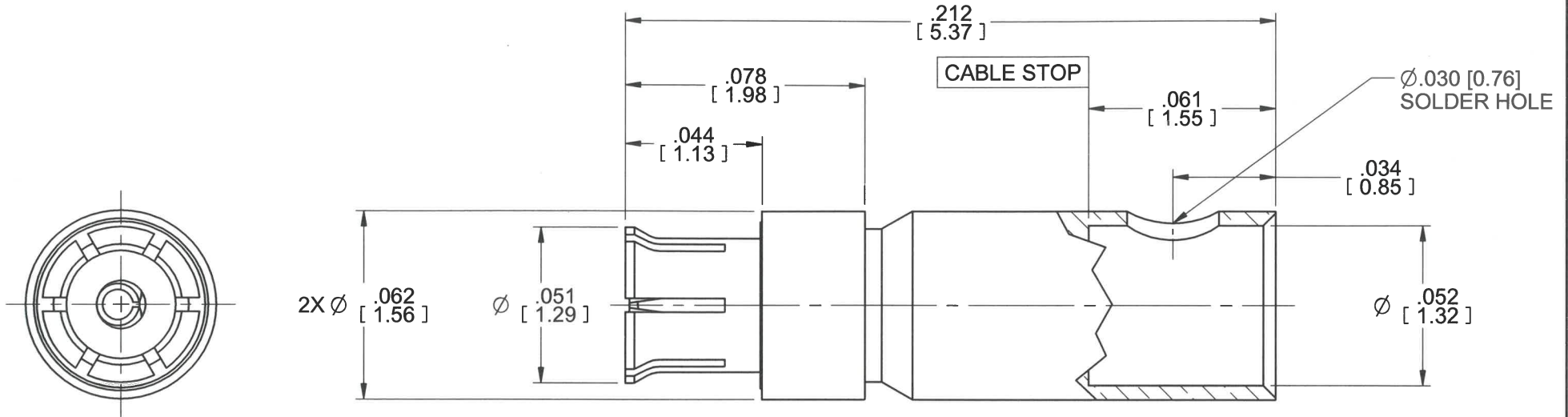

|                           |   |
|---------------------------|---|
| HOUSING:                  | BeCu UNS-C17300 PER ASTM B196/197<br>GOLD PLATE PER MIL-G-45204 TYPE II, GRADE C, CLASS 1 |
| OUTER AND CENTER CONTACT: | BeCu UNS-C17300 PER ASTM B196/197<br>GOLD PLATE PER MIL-DTL-45204, TYPE II, GRADE C       |
| CAPTURE BEAD:             | ULTEM 1000 PER ASTM D5205   |
| ITEM                      | MATERIAL & FINISH   |

1. ALL DIMENSIONS ARE IN INCHES. ALL ANGLES ARE IN DEGREES. DIMENSIONS SHOWN IN BRACKETS [XXX] ARE IN MILLIMETERS.

NOTES: UNLESS OTHERWISE SPECIFIED.

|   |         |  |                      |  |
|---|---------|--|----------------------|--|
| REV<br>A  | RELEASE | APRVD.<br>DE   | DATE:<br>5/26/23     | TITLE<br>54070-001B<br>SSBB SIZE 20 .047 DIRECT SOLDER<br>CABLE BULLET |
|  |         | Southwest Microwave, Inc.<br>9055 South McKemy Street<br>Tempe, Arizona 85284-2946<br>Telephone (480) 783-0201<br>Fax (480) 783-0360 |                      | DRN BY: JAC<br>DATE: 05/18/23<br>SCALE: 20:1<br>SHEET: 1 OF 1          |
|   |         |  | DWG. NO.<br>79Y70168 | REV.<br>A  |