

MODEL No.:

55053-006J

NOTE: Information herein is believed by Southwest Microwave, Inc. to be accurate. However, Southwest Microwave assumes no responsibility for any omissions or errors or inaccuracies for its use or for any infringements of patents or other rights of third parties that may result from its use. Data is intended for informational purpose only and does not constitute a contract of sale or any express or implied warranty, including any warranty of merchant ability or fitness for a particular purpose.

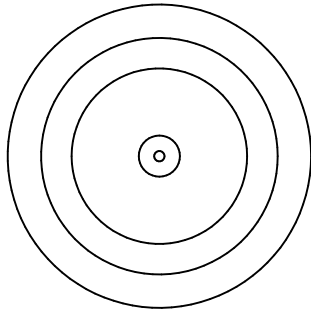

**DOCUMENT CONTROL
JUL 31 2024**

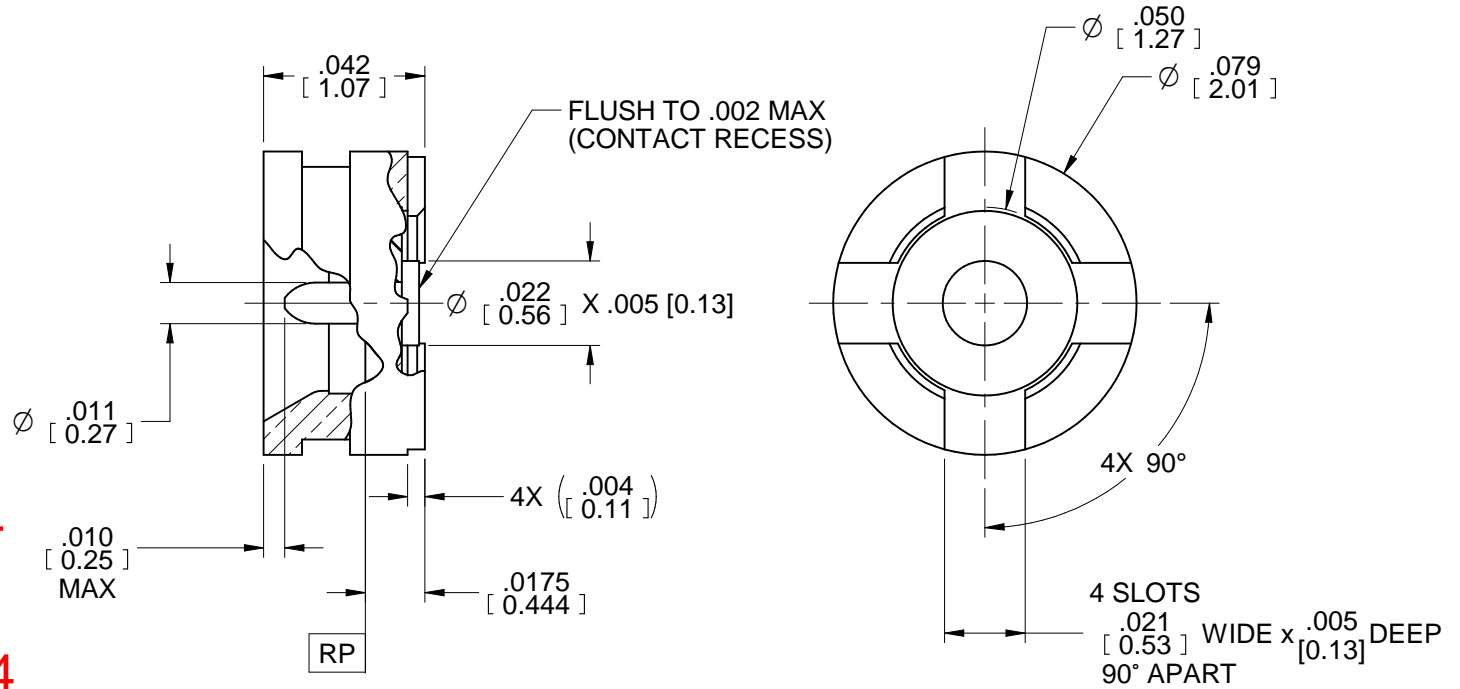

4. PCB GROUND PLANE AND CENTER CONTACT PAD SPECIFIC CONFIGURATIONS TO BE DETERMINED BY INDIVIDUAL APPLICATION REQUIREMENTS.

3. MATERIAL AND FINISH:

3.1 MATERIALS

HOUSING AND CENTER CONTACT:
BeCu ALLOY

DIELECTRIC BEAD:
PEEK HT

3.2 FINISHES

HOUSING AND CENTER CONTACT:
GOLD PLATE PER MIL-DTL-45204
- HOUSING: GOLD THICKNESS .000010 - .000025
- CONTACT: GOLD THICKNESS .000025 - .000040

2. CONNECTOR DESIGN IS COMPATIBLE WITH CURRENT MATERIAL AND PROCESS REQUIREMENTS FOR RoHS AND WEEE PER EUROPEAN COMMUNITY DIRECTIVE 2002/95/EC.

1. ALL DIMENSIONS ARE IN INCHES. ALL ANGLES ARE IN DEGREES. DIMENSIONS SHOWN IN BRACKETS [XXX] ARE IN MILLIMETERS.

NOTES: UNLESS OTHERWISE SPECIFIED.

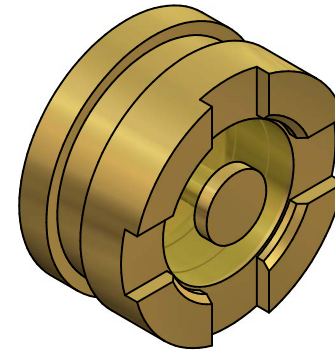
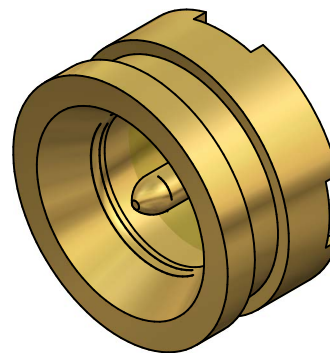

FSCM NO. 66049

REV. D	ECN 1000	ECN BY: JAC	APRVD: DE	DATE: 07/31/24	TITLE Super-Mini Board-to-Board VERTICAL MOUNT JACK (FEMALE), (DETENT) SURFACE MOUNT STRIPLINE LAUNCH			
 Southwest Microwave, Inc. 9055 South McKemy Street Tempe, Arizona 85284-2946 Telephone (480) 783-0201 Fax (480) 783-0360					DRN BY: EJO	DATE: 4/7/15	MODEL NO. 55053-006J	REV. D
					SCALE 20:1		DWG. NO. 79BB62569	
					SHEET: 1 OF 1			