

DWG No.:

91B60811

NOTE: Information herein is believed by Southwest Microwave, Inc. to be accurate. However, Southwest Microwave assumes no responsibility for any omissions or errors or inaccuracies for its use or for any infringements of patents or other rights of third parties that may result from its use. Data is intended for informational purpose only and does not constitute a contract of sale or any express or implied warranty, including any warranty of merchant ability or fitness for a particular purpose.

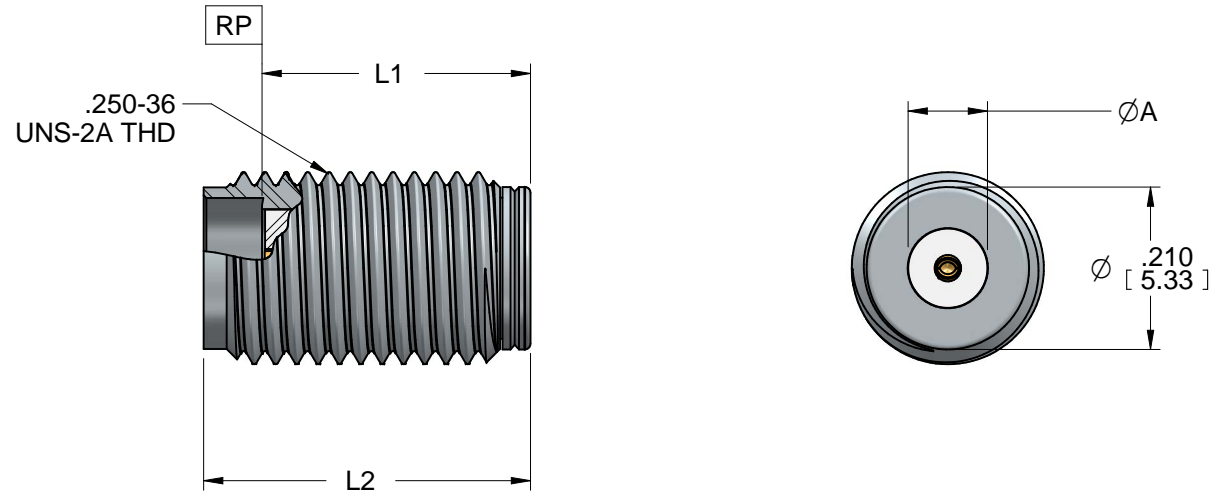

HOUSING:	STEEL, CRES ALLOY UNS-S30300 PER ASTM A582 PASSIVATED PER ASTM A967
CONTACT:	BeCu UNS-C17300 PER ASTM B196 GOLD PLATE PER ASTM B488
DIELECTRIC:	VIRGIN PTFE FLUOROCARBON PER ASTM D1710, TYPE 1 GRADE 1, CLASS B
CAPTURE BEAD:	ULTEM 1000 PER ASTM D5205
ITEM	MATERIAL & FINISH

Model	Pin Size	Max. Pin Depth	L1	L2	Ø A
220-503SF	.036	.100	.349	.425	.1540
220-502SF	.020	.100	.349	.425	.1045
220-506SF	.018	.100	.349	.425	.1020
220-501SF	.015	.100	.349	.425	.0765
220-500SF	.012	.075	.349	.425	.0765
220-507SF	.009	.065	.349	.425	.0602
220-512SF	.020	.100	.314	.390	.1045
220-517SF	.018	.100	.314	.390	.1020
220-516SF	.015	.100	.314	.390	.0765
220-511SF	.012	.075	.314	.390	.0765

2. SEE DOCUMENT NO. 91B60792 FOR PRODUCT SPECIFICATIONS.
1. ALL DIMENSIONS ARE IN INCHES. ALL ANGLES ARE IN DEGREES.  
DIMENSIONS SHOWN IN BRACKETS [XXX] ARE IN MILLIMETERS.
- NOTES: UNLESS OTHERWISE SPECIFIED.

REV B	ECN 891	ECN BY JAC	APRVD. DE	DATE: 04/26/23	TITLE <b>SMA Jack (Female) Thread-In</b>		
 Southwest Microwave, Inc. 9055 South McKemy Street Tempe, Arizona 85284-2946 Telephone (480) 783-0201 Fax (480) 783-0360					DRN BY: EAG	DATE: 4/20/12	DWG. NO. <b>91B60811</b>
					SHEET: 1 OF 1		REV. <b>B</b>